

071306T4EIN

Electrical Installation Technician Level 6

ENG/OS/EIT/CC/04/6/A

Prepare and Interpret Technical Drawings

July/August 2023



**TVET CURRICULUM DEVELOPMENT, ASSESSMENT AND CERTIFICATION
COUNCIL (TVET CDACC)**

WRITTEN ASSESSMENT

3 HOURS

INSTRUCTIONS TO CANDIDATES

1. This paper has two sections **A** and **B**. Answer questions in each section as per instructions given in the section.
2. You are provided with a separate answer booklet.
3. Marks for each question are indicated in the brackets.
4. Do not write on the question paper.

This paper consists of six (6) printed pages

Candidates should check the question paper to ascertain that all the pages are printed as indicated and that no questions are missing.

SECTION A: (40 MARKS)

Answer **ALL** the questions in this section

1. Illustrate a method of dividing a line measuring 90 mm into **seven** equal divisions. (5marks)
2. Construct a regular hexagon given the length of one side to be 50 mm. (6 marks)
3. State **four** precautions in handling a T-square. (4 Marks)
4. With the aid of sketches, describe **three** types of dimensions in technical drawing. (3 Marks)
5. Sketch the following workshop tools. (6 marks)
 - a) Hammer
 - b) Pliers
 - c) Hack saw
6. The diagram below shows a part of a machine viewed while standing from the arrow side. Analyze the diagram and sketch the following views including all the necessary details.

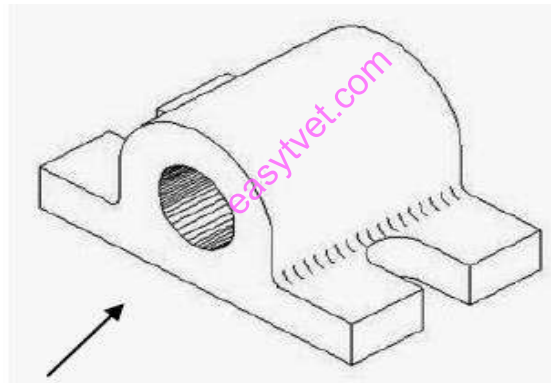

Figure 1

- a) Front view from arrow side (4 Marks)
- b) Plan (4 Marks)
7. List **two** safety precautions to be adhered to while using drawing instruments. (2 Marks)
8. With the aid of a symbol, distinguish between first angle projection and third angle projection. (4 Marks)
9. Draw 50mm lines to differentiate between the following lines; (2 Marks)
 - a) Sectioning line
 - b) Hidden line

SECTION B: (60 MARKS)

Answer any **three** questions from this section

10. Figure 2 shows a mechanical component, draw the following in first angle projection

- a) Front elevation in direction of arrow x
- b) End elevation
- c) Plan

(20 Marks)

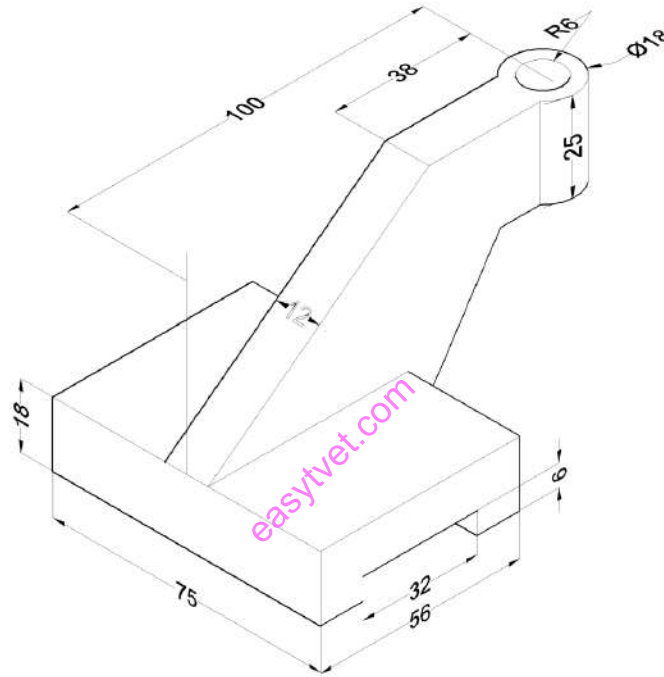

Figure 2

11. Figure 3 show a branched cylindrical pipe. Draw the complete plan, front elevation and the surface development for main pipe and the branch pipe. (20 Marks)

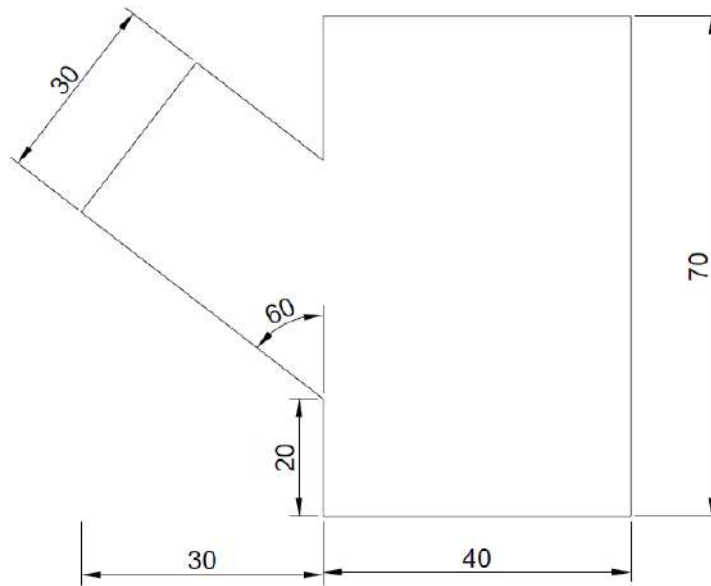

Figure 3 Branched cylindrical pipe

12. Figure 4 below shows a machine block drawn in isometric projection. Draw in first angle projection the following views. (20 Marks)

- a) Sectional front elevation along cutting plane X-X
- b) Plan
- c) Include four major dimensions

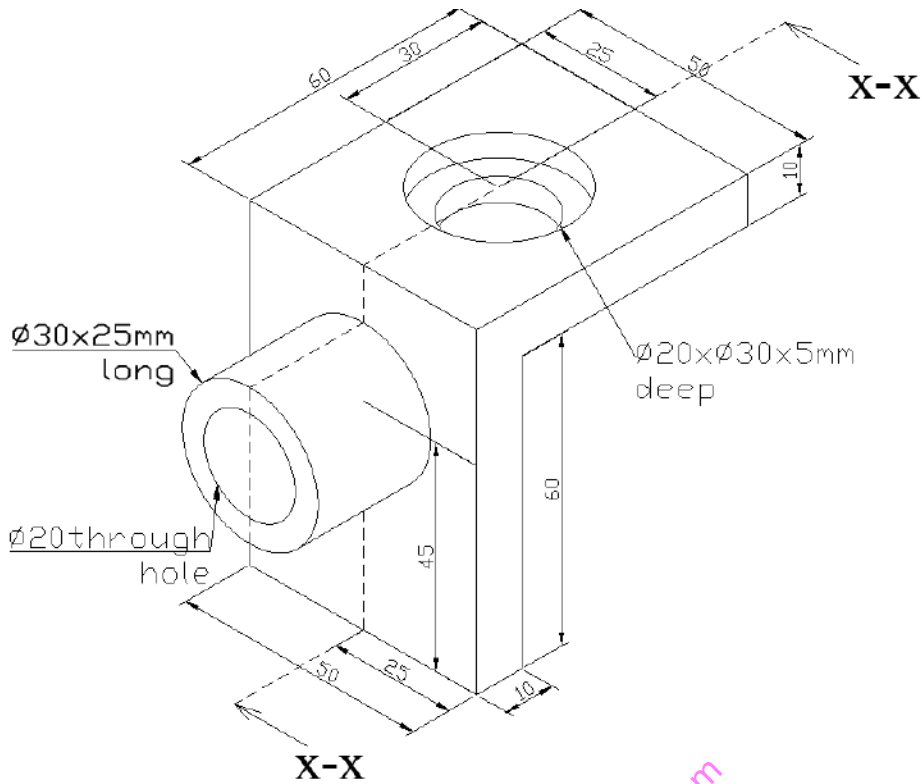

Figure 4

13.

- Figure 5 represents an electrical installation layout. Draw the wiring diagram such that switch 1 controls lamp 1 and either switch 2, switch 3 or switch 4 controls lamp 2 and lamp 3 independently. (12 Marks)
- Draw the following types of lines. (2 Marks)
 - Long break line
 - Center line

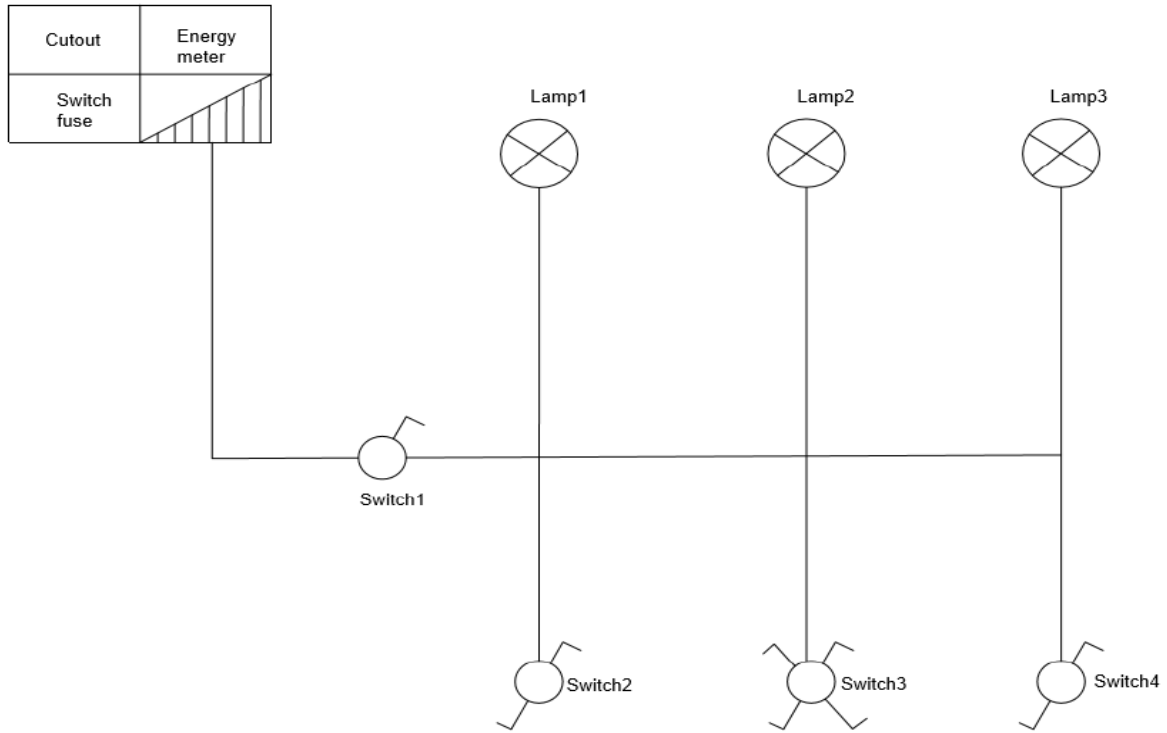

Figure 5 Layout diagram

c) Figure 6 below is an elevation of the turning handle of a can opener. Draw this view. Twice-full size, showing clearly the method of establishing the centers of the arcs. (6 Marks)

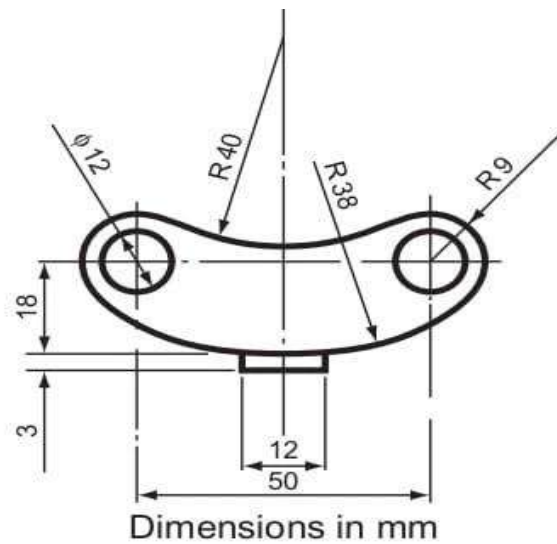

Figure 6 Turning handle

THIS IS THE LAST PRINTED PAGE