

1920/202B
COMPUTER APPLICATIONS II (PRACTICAL)
Paper 2
November 2017
Time: 2 hours



THE KENYA NATIONAL EXAMINATIONS COUNCIL
CRAFT CERTIFICATE IN INFORMATION TECHNOLOGY

MODULE II

COMPUTER APPLICATIONS II (PRACTICAL)

Paper 2

2 hours

INSTRUCTIONS TO CANDIDATES

*You have **Ten** minutes to read through the **instructions** and **questions** before starting the examination.*

*Any **problem** with the computer should be reported to the **invigilator** immediately.*

*Direct any question(s) to the **invigilator** only. Conversing with fellow students may lead to disqualification.*

Write your name and index number on the Rewritable CD.

Type your name and Index Number as a header on each sheet of paper used.

*This paper consists of **THREE** tasks. Perform **ALL** the tasks.*

*Each task carries **20** marks.*

Read the instructions of each task carefully.

Print on one side of the paper(s) only and use a fresh sheet of paper for each task.

*Hand over your **printed work** and the **Rewritable CD** to the invigilator at the end of the examination.*

This paper consists of 6 printed pages

Candidates should check the question paper to ascertain that all the pages are printed as indicated and that no questions are missing.

©2017 The Kenya National Examinations Council

GENERAL INSTRUCTIONS TO CANDIDATES

1. Create a folder named **KNECEXAM** on the desktop.
2. Ensure that the **KNECEXAM** folder and all its content is burnt onto the Rewritable CD.

Task 1

Figure 1 shows a table mat design. Use it to answer the questions that follow:

- (a) Open a CAD program and set the drawing units to millimeters. (½ mark)
- (b) Insert *four* layers with the following properties:
 - (i) *Outline* layer, with a line weight of 0.6mm; (1 mark)
 - (ii) *Centre line* layer, blue in colour; centre line type; (1 mark)
 - (iii) *Dimensions* layer, red in colour with a line weight of 0.15; (1 mark)
 - (iv) *Construction* layer, white in colour with a default line weight. (1 mark)
- (c)
 - (i) Draw the table mat design using the dimensions given on the outline layer; (7 marks)
 - (ii) Draw the centerlines on the centerline layer; (1 mark)
 - (iii) Fully dimension the drawing on the dimensions layer; (5 marks)
 - (iv) Hatch the drawing on the construction layer. (1 mark)
- (d) Save the drawing as *Table Mat* in the **KNECEXAM** folder. (½ mark)
- (e) Open layout 1, balance the drawing on the layout page and print. (1 mark)

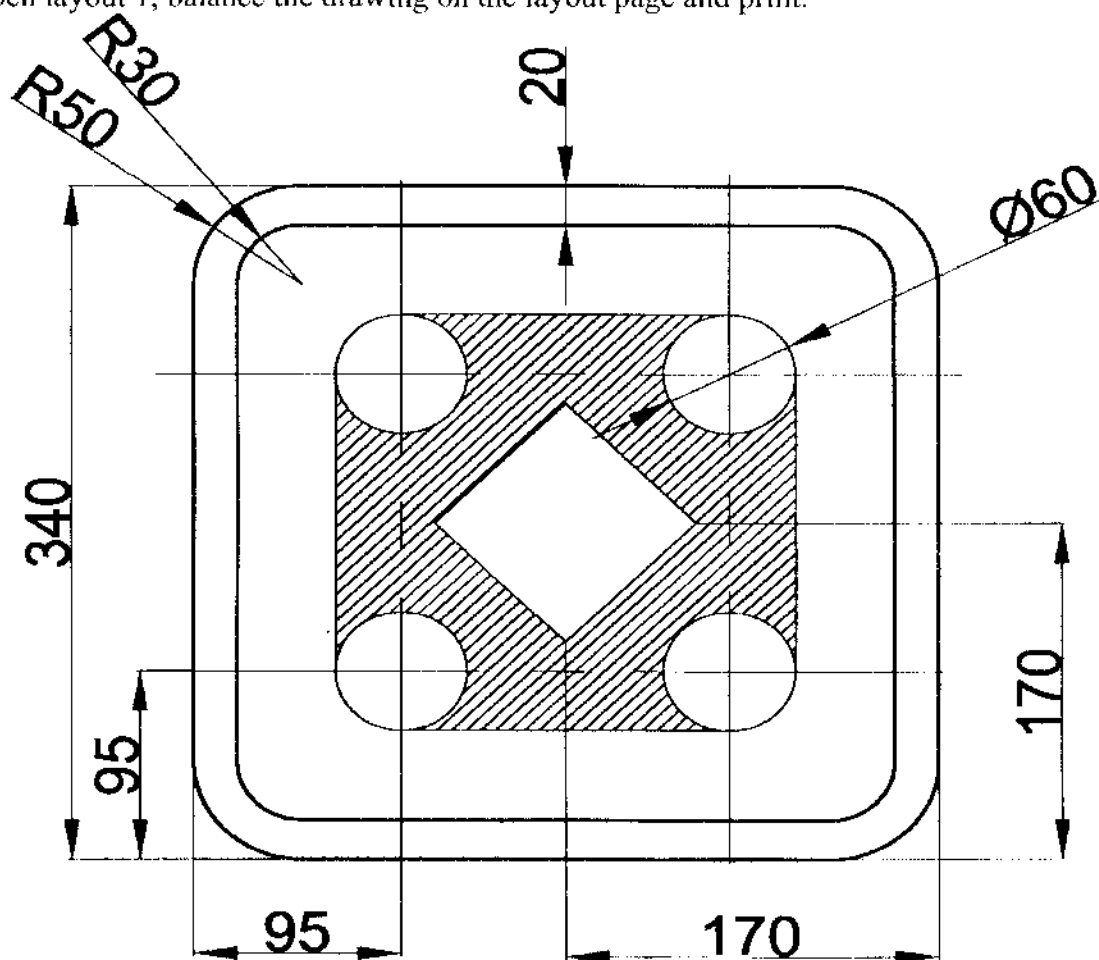

Figure 1

Task 2

Figure 2 shows a publication designed using a DTP program. Use it to answer the questions that follow:

- (a) Open a DTP program and make the following page settings:
- (i) Page orientation: landscape; (½ mark)
 - ii) Paper size A4. (½ mark)
- (b) Create the publication to appear as shown in Figure 2, ensuring that the publication covers the entire printable area of the paper size. (18 marks)
- c) Save the publication as *Certificate* in the **KNECEXAM** folder to print out later. (1 mark)

<h1>POGBA SPORTS ACADEMY</h1>		
<i>P. O. Box 112277—10008, Gakoromone E-mail: info@pogbasports.com</i>		
<h2>Certificate of Participation</h2>		
This is to Certify That		
.....		
Participated in a Soccer Clinic		
Held between 14 th and 18 st February 2017		
Signature	PATRON	Date
Signature	SECRETARY	Date

POGBA SPORTS
ACADEMY

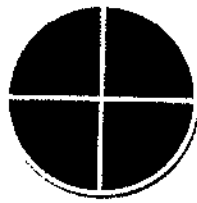

Figure 2

Task 3

Haraka Limited of P. O. Box 64184-00420, Nakuru, provides courier services to several customers in Nakuru County. Record the following financial details and transactions of the company using an accounting program for the year starting 1st October, 2016.

Balances as at 1st October 2016	Ksh
Motor Cycles	200,000
Motor Vehicles	6,000,000
Creditors; KD Motors	240,000
Jui Petrol Station	100,000
Debtors; Naita Travels	600,000
Mwita limited	320,000
Bank (Letu)	106,000
Cash	90,000

The following transactions took place during the month of October 2016.

Invoices received

Oct 10	Gonga Garage for vehicle maintenance Ksh 34,000
Oct 28	Sakua Motorcycles for a motorcycle Ksh 86,000

Invoices Issued

Oct 20	Kavilu Contractors for Courier services Ksh 140,000
Oct 25	Eldoret Travels for Courier services Ksh 20,000

Cash Sales

Oct 20	Courier services subcontract Ksh 40,000
Oct 30	Courier services for Maku Bank Ksh 180,000

Debit Notes Issued

Oct 31	Courier services Maku Bank Ksh 50,000
--------	---------------------------------------

Cash payments

Oct 14	Wages Ksh 60,000
Oct 29	Electricity Ksh 24,000, vehicle maintenance Ksh 16,000

Cheque receipts

Oct 20	Naita Travels Ksh 200,000
Oct 28	Mwita limited Ksh 156,000
Oct 31	Kavilu Contractors Ksh 100,000

Cheque payments

Oct 26	Sakua Motorcycles Ksh 86,000
Oct 31	KD Motors Ksh 240,000

Generate and print each of the following reports:

- a) Opening Balance sheet (5 marks)
- b) Income statement for the month (7 marks)
- c) Closing trial balance (8 marks)

THIS IS THE LAST PRINTED PAGE.