

## CHAPTER 1: EXECUTING SUBSTRUCTURE WORKS

**Unit of learning code:** CON/CU/BUT/CR/05/6

**Related Unit of Competency in Occupational Standard:** This unit addresses the unit of competency: perform substructure works

### 1.1 Introduction to the unit of learning

This unit describes the competences required to perform substructure work. It involves setting out the building, excavating foundation, laying building foundation, erecting foundation walls, constructing solid ground floor and finishing substructure works.

### 1.2 Summary of Learning Outcomes

1. Set out the building
2. Excavate foundation trench
3. Lay building foundation
4. Erect foundation walls
5. Construct solid ground floor

#### 1.2.1 Learning outcome 1: Set out the building

##### 1.2.1.1 Introduction to the learning outcome

This learning outcome specifies the content of competencies required to Set out the building. It includes site investigation/surveying, building drawings and interpretation, construction dimensions, setting out tools and equipment, setting out procedure and building codes.

The trainee is expected to interpret building drawing as per the working drawing, take ground measurement as per the working drawing, mark position of walls and columns as per the foundation plan, erect and mark profile boards as per the plan and determine accuracy of setting out as per the architectural and structural details.

##### 1.2.1.2 Performance Standard

1. Building drawings are interpreted as per working drawings
2. Ground measurement are taken as per the working drawings
3. Position of walls and columns are marked as per foundation plan
4. Profile boards are erected and marked as per the plan
5. Accuracy of setting out is determined as per architectural and structural details

##### 1.2.1.3 Information Sheet

###### Site preparation

Before the commencement of actual building construction, there is the need to conduct certain preliminary site activities. This is to enable the building team have foreknowledge of a site. Some activities which preceded the actual building construction are:

- **Site Investigation and Organization –**

A site investigation simply is the process of the collection of information, the appraisal of data, assessment, and reporting without which the hazards in the ground beneath the site cannot be known. The investigation enables the contractor or the engineer to precisely have an idea

about the site and assess if there are peculiar problems to the proposed contract. It is this initial understanding of these problems that the engineer will use to design the building to suite the site. Similarly, the contractor could plan and organize his activities, sufficiently to achieve success and minimize time. This is done by producing a site layout plan and placing equipment and materials in specific positions for easy reach, handling and utilization.

Factors to be considered by the contractor during reconnaissance and layout prior to constructional works are:

- i. Availability and means of access to the site whether by road, rail or waterway.
  - ii. Availability of suitable materials/equipment and spare available for erecting plant and or storing materials around the site.
  - iii. Availability of space to erect temporary site offices and welfare facilities.
  - iv. The effect of vibration on adjacent structure when the construction involves using heavy/massive equipment (e.g. in piling) should be considered.
  - v. The availability of water and power supply should be ascertained and the rate of payment investigated.
  - vi. Knowledge of the nature and type of soil, and the level of water table are important as the way necessitate subsoil drainage and cause flooding.
  - vii. The local planning authorities should be approached to ascertain whether there is any special or significant restriction which could adversely affect the development of site (e.g. underground cables).
  - viii. Valuable information can be obtained by talking with the local inhabitants of the area.
  - ix. Any special condition that may limit work in anyway should be noted and taken care of e.g. weather or climatic condition.
- **Subsoil Exploration (Trial boreholes) –**

This is the process of determining the layers of natural soil deposits that will underlie a proposed structure and their physical properties. It is an important part of an early site investigation. The building design and structural loading can be related to the detailed and thorough examination of the subsoil bearing potential (ability to withstand load). Preliminary examination may be with trial pits excavated by spade or a hand auger. When more detailed information is required, a powered auger is more effective. The depth of boreholes can be several meters deep for high rise buildings, and boring can be at random or regular intervals. Samples of subsoil can be extracted loose or distorted, or undisturbed in steel tubes. They are recorded on a borehole log, and samples are then taken for laboratory analysis to establish the moisture content, bearing capacity and chemical composition.
  - **Site Welfare Facilities –**

The provision of shelter and accommodation for taking meals and deposition of clothes is a basic requirement on all sites. The builder should provide a hut for workmen so that meals and short rest can be taken, and also for storage of clothing not required for work during the day and protective clothing at night. The mass room or canteen should be convenient for washing facilities. Adequate wash basins, troughs and showers with soaps and towels are required. (An isolated sanitary facility with

water closets is also required). Provision for first aid is also very important, and every contractor must provide first-aid accommodation to include a couch, stretchers, bandages, blankets, equipment, etc. a trained person in first-aid treatment is to be available on site during working hours.

- **Storage and Protection of Materials –**  
Materials such as cement, timbers, bricks and blocks should be protected from weather by storing in a shed or well stacked in a suitable position on the site, where they will not be liable to damage and are adequately protected. Electrical and plumbing (sanitary) fittings should be kept in a locked shed to avoid theft or breakage. Proper storage is necessary because saturated cement with time sets and becomes hardened resulting to wastage. Saturation also affects the mortar or concrete strength. Water is readily absorbed by timber causing deformation and rot, this should be avoided. A saturated brick or block will be very difficult to handle. They should be well protected.
- **Site Fencing and Hoardings –**  
A permanent fence or temporary hoardings will be required around the site. This is a barrier made of block wall, wooden or metal stalk or rail or wire in some cases used old zinc to provide security and protect equipment and materials, and to keep out intruders. It also protects the ugly sight of construction and preserves the beauty till completion. The hoardings are removed after the completion of the project. The hoardings should be well erected and in sage order so as not to cause injury to workers or passé.
- **Site Clearance excavation to soil –**  
The site should be cleared of the bushes, shrubs, trees, etc. which are on the building position and around the storage and temporary facilities area. The roads should be grubbed up and completely removed. Before any building is erected, it is essential that the area to be occupied by the building has the vegetable top soil removed from site completely or placed on one side, and spread level over areas after completion of the project to provide gardens. The organic content of the vegetable soil may be injurious to concrete, and so it should never be used for backfilling, or making up levels under the building. The path of excavation of topsoil is normally 150mm. leveling; land clearance and stripping of the topsoil are all easily achieved with a bulldozer.
- **Ground Water Control –**  
Excavation and sample boreholes frequently reveal and locate a level of saturation within a few meters below the surface. This is known as the water table and it varies with season. Excavation below the water table will be difficult and the strength of any concrete placed in water will be seriously affected. A pre-knowledge of this fact helps the contractor to be equipped and prepare with his diesel-powered water pump for the temporary removal of water during excavation and concreting.

## **Interpretation of building drawings**

### ➤ **Site Plans –**

A site plan is a large scale drawing that shows the full extent of the site for an existing or proposed development. It is used to locate site, buildings, define site levels, indicate services to buildings, and identify parts of site such as roads, footpaths and boundaries and to give setting out dimensions for the site and buildings as a whole. Suitable scale not less than 1: 2500

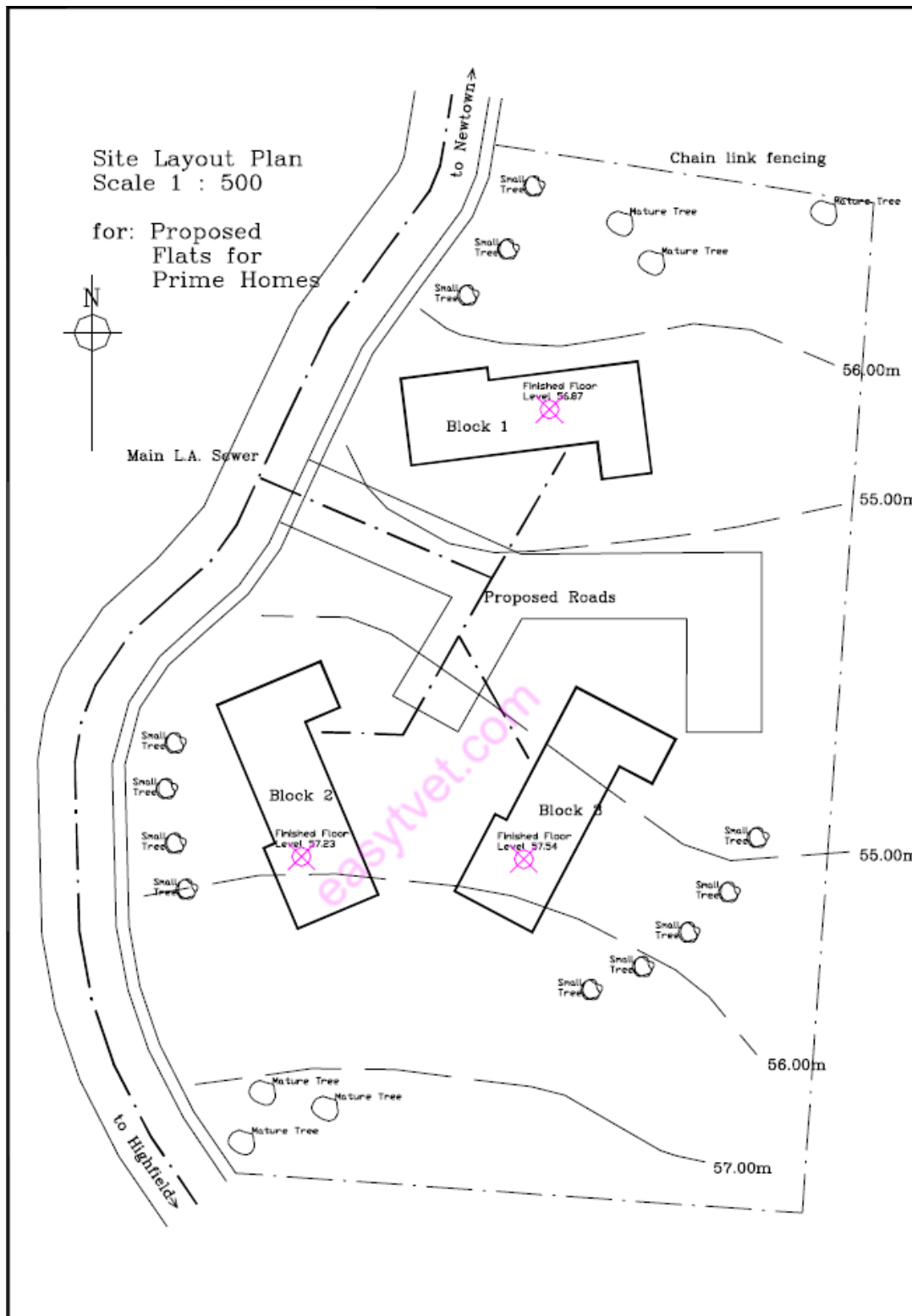

Fig. 1- Site Layout Plan Sscale 1:500 ( for Proposed Flats for Prime Homes )  
 Ref. [https://www.designingbuildings.co.uk/wiki/Site\\_plan](https://www.designingbuildings.co.uk/wiki/Site_plan)

➤ **Floor Plans :-**

Floor plans are 2D-scale drawings that show the relationship between rooms, spaces and physical features viewed from above. They are used to identify and set out parts of the building such as rooms, corridors, doors, windows, etc., Suitable scale not less than 1: 100

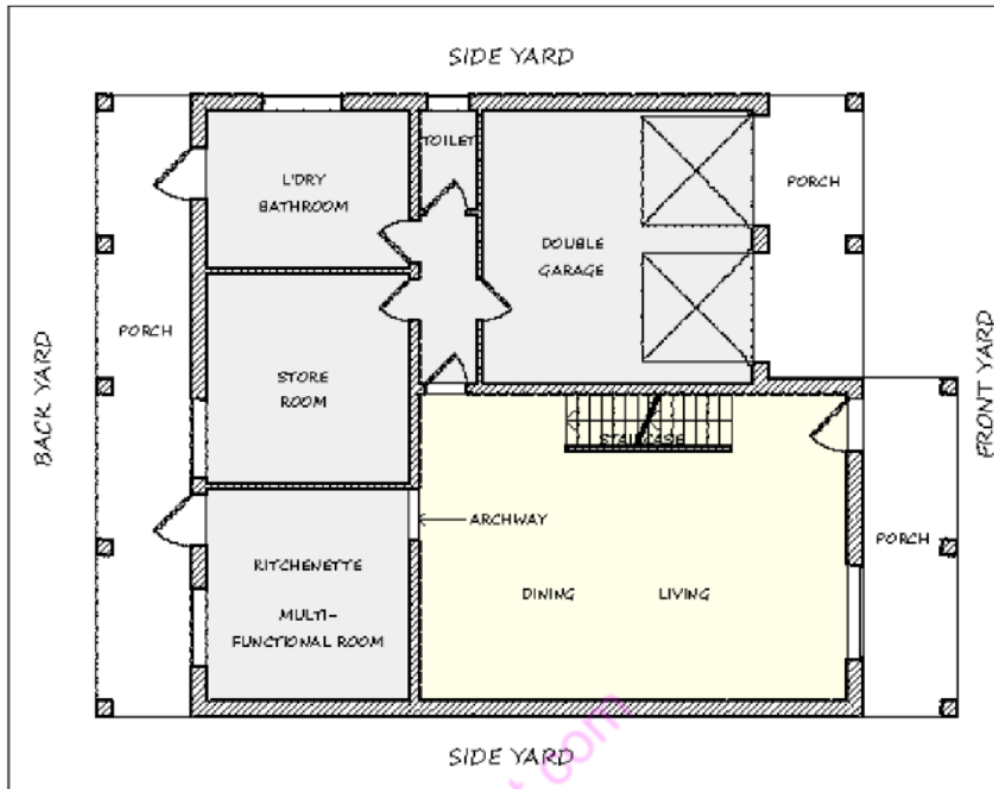

Fig. 2. Schematic ground floor plan.

Ref. [https://www.researchgate.net/figure/Schematic-ground-floor-plan-Drawing-by-the-author\\_fig5\\_320912123](https://www.researchgate.net/figure/Schematic-ground-floor-plan-Drawing-by-the-author_fig5_320912123)

### ➤ Elevations –

An **elevation drawing** is an orthographic projection **drawing** that shows one side of the **house**. The purpose of an **elevation drawing** is to show the finished appearance of a given side of the **house** and furnish vertical height dimensions. Four **elevations** are customarily drawn, one for each side of the **house**.

It is used to identify doors and windows. Suitable scale not less than 1: 100

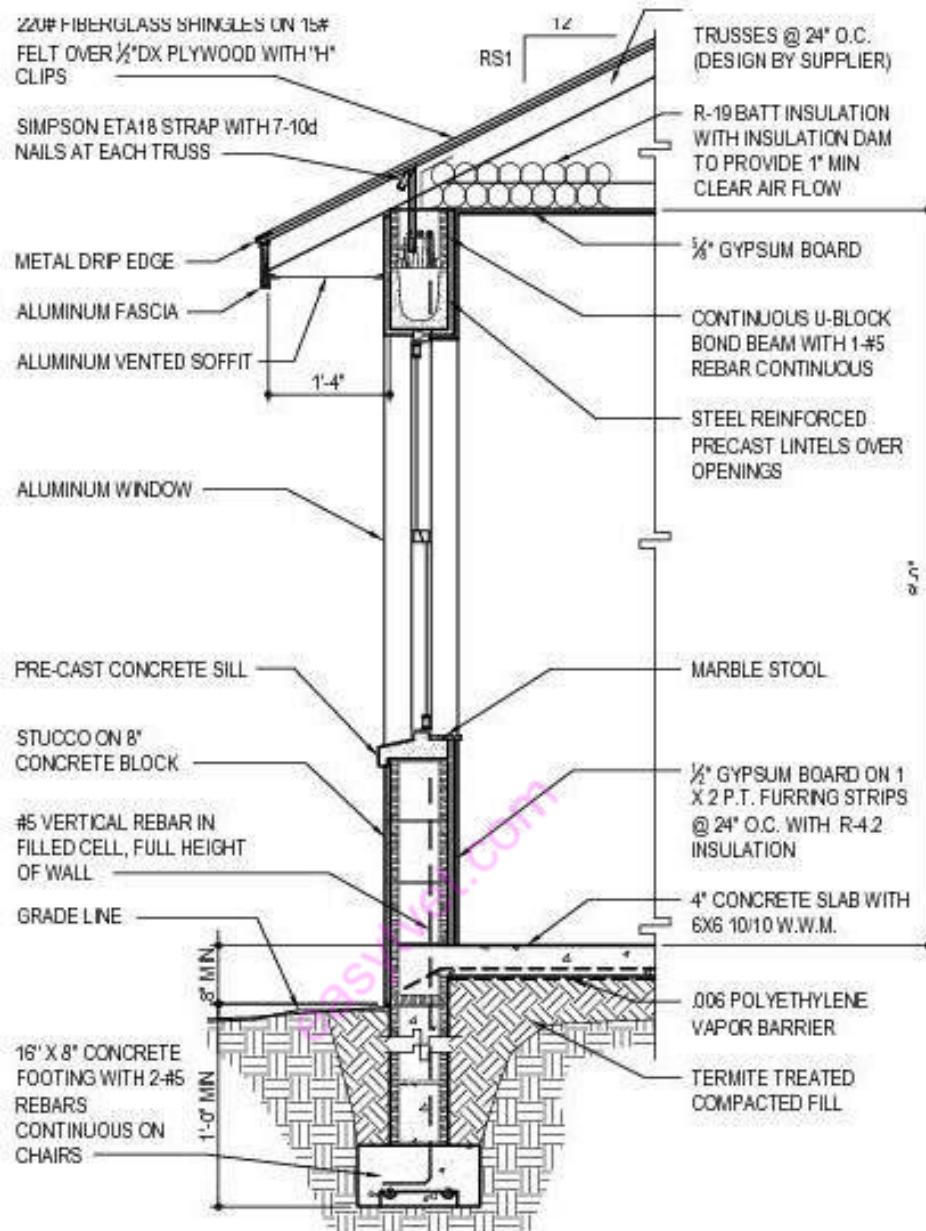

Fig. 3 . Architectural Elevations

Ref. [https://cdn.jhmrاد.com/wp-content/uploads/drawing-house-planssports-picks-pro\\_143083.jpg](https://cdn.jhmrاد.com/wp-content/uploads/drawing-house-planssports-picks-pro_143083.jpg)

➤ **Sections** –

A ‘section drawing,’ ‘section,’ or ‘sectional drawing’ is a 2-D scale drawing which shows a view of a structure as though it had been sliced in half or cut along another imaginary plane. It is used to provide vertical views through the building to show method of construction. Suitable scale not less than 1: 50



**1** **TYPICAL WALL SECTION**  
 3/4" = 1'-0" CR/L-030

**Fig. 4. Typical wall section**

Ref . <https://www.pinterest.com/pin/788059634780510433/>

➤ **Component Drawings –**

**Component drawings are 2-D drawings which provide detailed information about the individual units.** They may be drawn at large scales such as; 1:10, 1:5, 1:2, 1:1, and so on. **They** might describe units such as; beams, windows, doors, sills, coping stones, and so on. They are used to identify and supply data for components to be supplied by a manufacturer or for components not completely covered by assembly drawings. Suitable scale range 1: 100 to 1: 1.



## Wood Windows

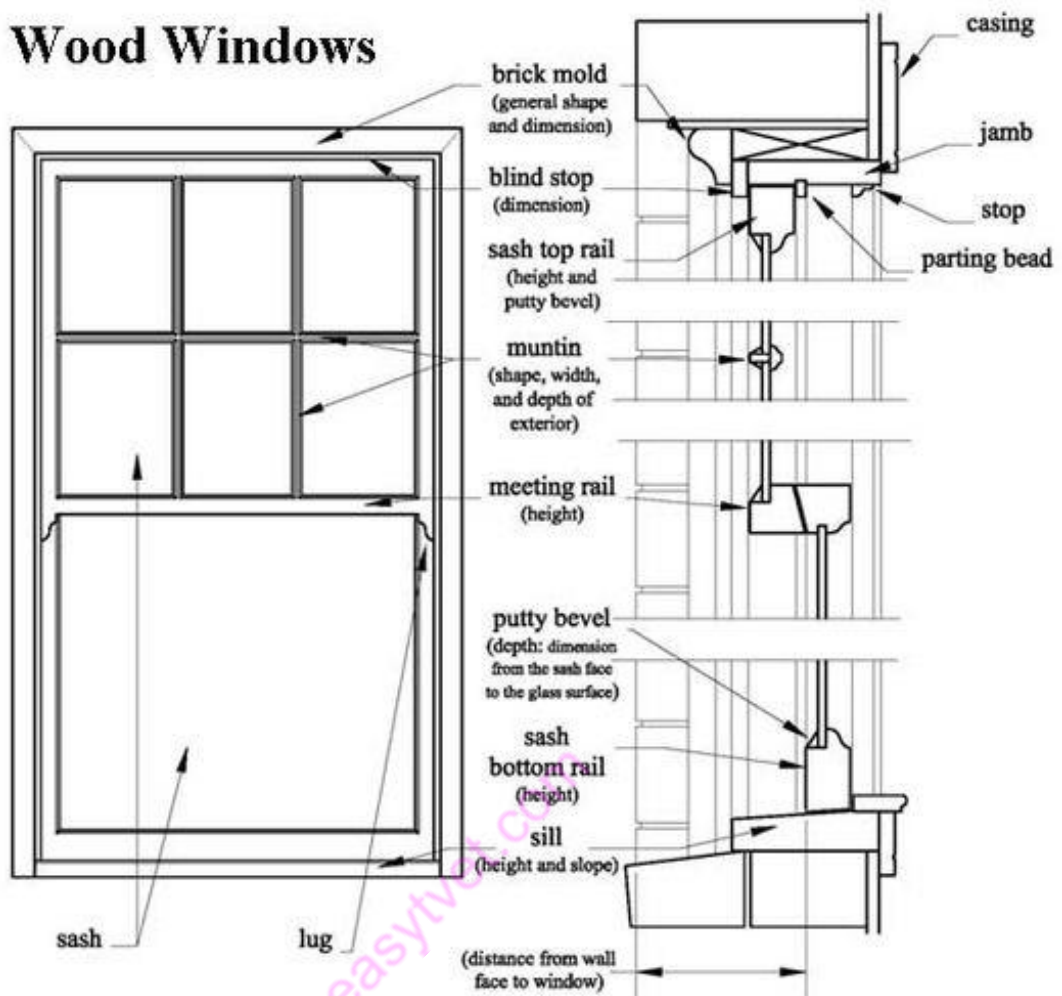

Fig. 5 sash Window component

Ref. <https://www.pinterest.com/pin/231302130836447163/>

### ➤ Assembly Drawings –

These are drawings which shows how the components fit together to form an Item or Element. These Drawings may include, orthogonal plans, sections and elevations, or three-dimensional views, showing the assembled components, or an exploded view showing the relationship between the components and how they fit together. Suitable scale range 1: 20 to 1: 5

All drawings should be fully annotated, fully dimensioned and cross referenced.

Sketch - this can be defined as a draft or rough outline of an idea, it can be a means of depicting a three-dimensional form in a two-dimensional guise. Sketches can be produced free-hand or using rules and set squares to give basic guide lines.



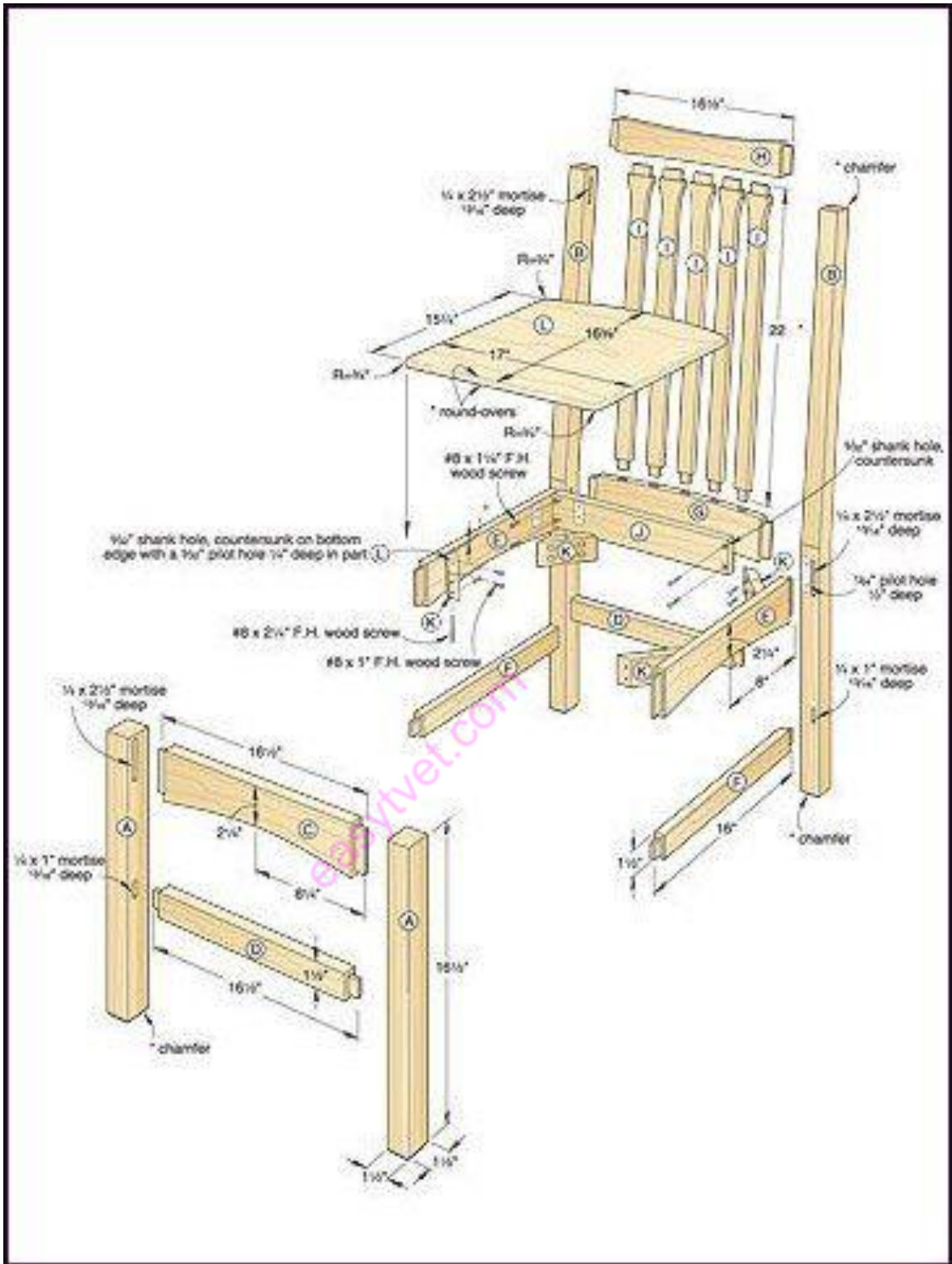

Fig. 6 wooden chair Assembly drawing

Ref. <https://www.pinterest.com/pin/855261785465493885/>

➤ **Detail drawings:-**

Detail drawings provide a detailed description of the geometric form of a part of an object such as a building, bridge, tunnel, machine, plant, and so on. They tend to be

large-scale drawings that show in detail parts that may be included in less detail on general arrangement drawings.

Detail drawings usually at a scale of around 1:20, 1:10 depending on the project and information. These will demonstrate junctions, complex parts of the build, typical details and anything else that will assist the contractor in executing the build effectively. ( see fig. 2 below).

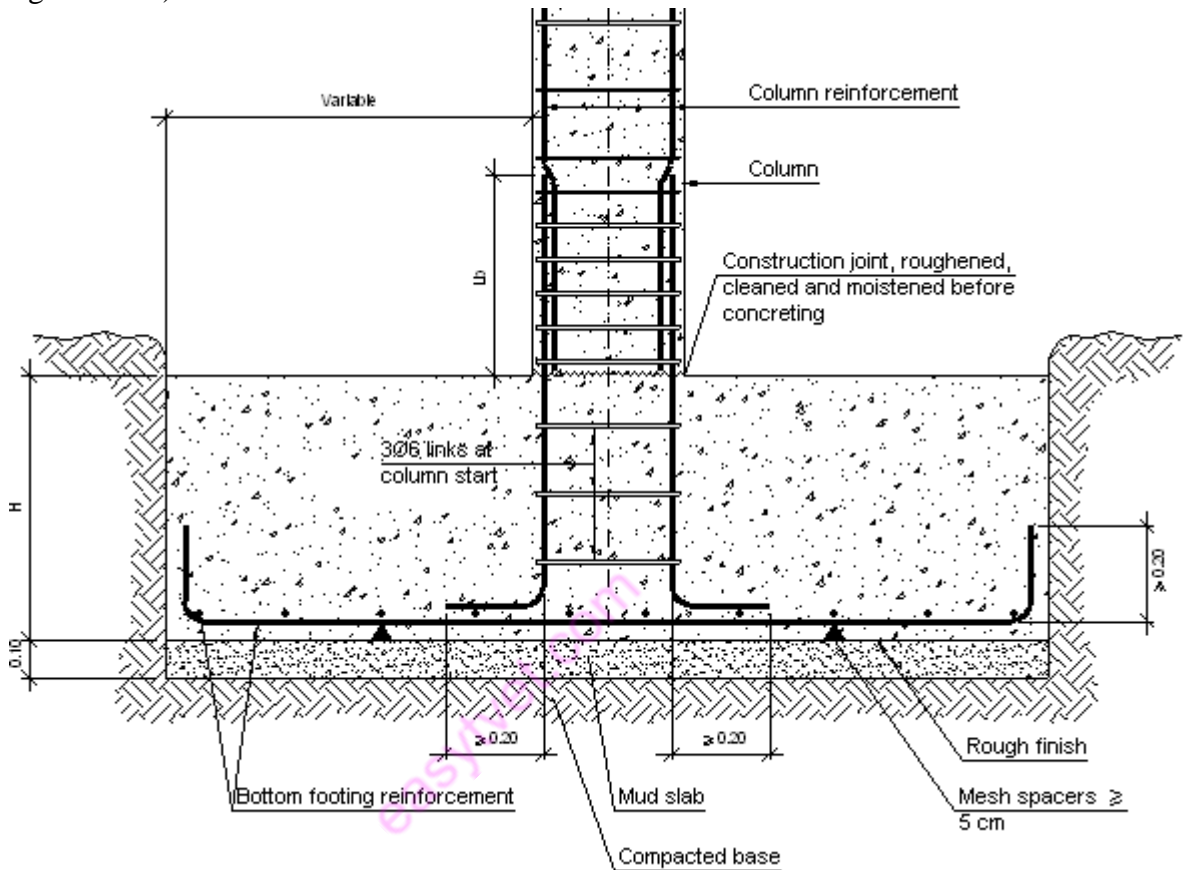

**Fig . 7. -Pad foundation detail drawing**

Ref. <http://constructiondetails.us.cype.com/CSZ001.html>

### 1.2.3.1 Setting Out and Leveling –

**What is setting out?** It is the process of developing the physical positions of corners and walls of a building, and it's done by transferring dimensions from the layout plan to the ground.

The main function of setting out is to establish the position of the trench and wall of the house as well as the position of corners and rooms.

After the stripping of the topsoil and general site leveling, it is important that the structure is built in the correct position as shown on the architect's drawings. The position of a building is marked out with string lines and pegs to indicate foundation trenches and walls. The frontage line (building line) is an imaginary line shown on the site plan, or determined by the local authority, set back from the Centre line of the road way.

**What is leveling ? Levelling** is a process of determining the height of one level relative to another. It is used in surveying to establish the elevation of a point relative to a datum, or to establish a point at a given elevation relative to a datum.

#### Method of Setting Out

- 3-4-5 Method -

This is based on the mathematical principle that any triangle with the sides in the ratio of 3-4-5 is a right angle. The method is as follows: first you determine the building line and established one corner of the building by driving a peg at that point. A tape is used to measure a distance of 3m along the building line and a second peg is established with a nail on top. The ring of the tape is held over the second peg with the 12m mark of the tape. With an assistant and with the 3m mark of the tape around the corner peg, the tap is then stretched out to give the position of the third peg at 7m mark. Now a line can then be extended through third peg to give the width of the building. The line extended should be perpendicular or 90° to the building line. The above procedure is also carried out for the rest corners and any possible intersection within the building. To check the accuracy of the four-sided figure formed, the diagonals should be measured to be equal in length.

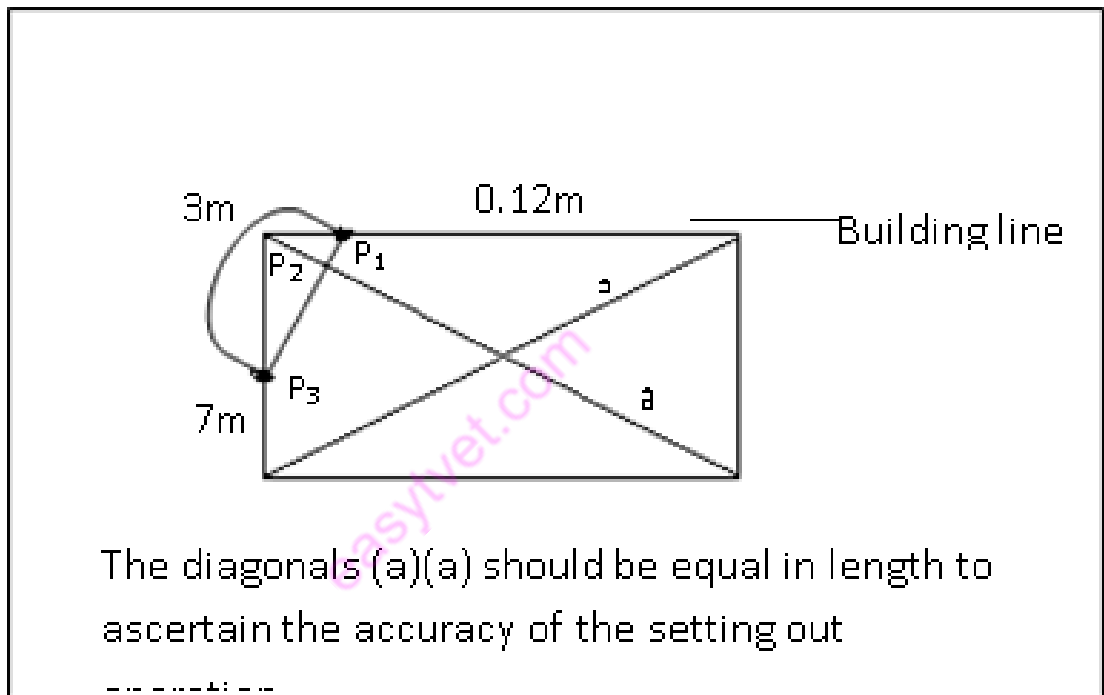

Figure 8: an illustration -01 of setting out using 3-4-5 method.

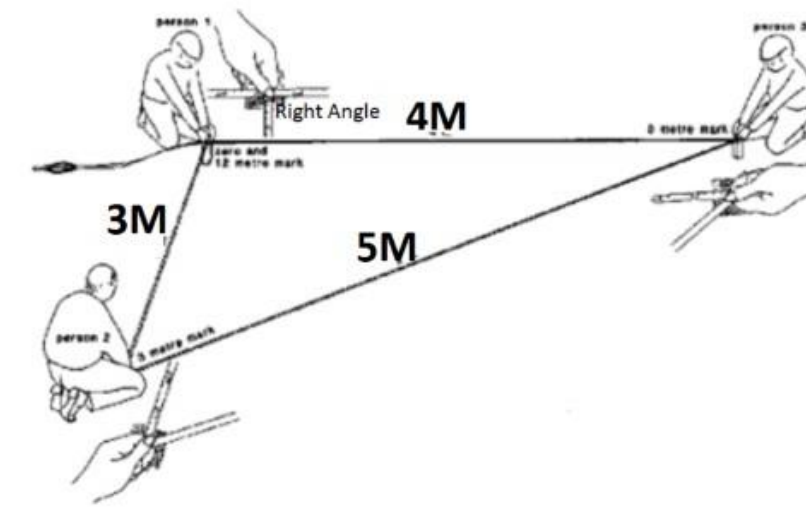

Fig .9 an illustration -02 of setting out using 3-4-5 method.

Ref. <https://engineeringbasic.com/steps-in-setting-out-a-building-plan/>

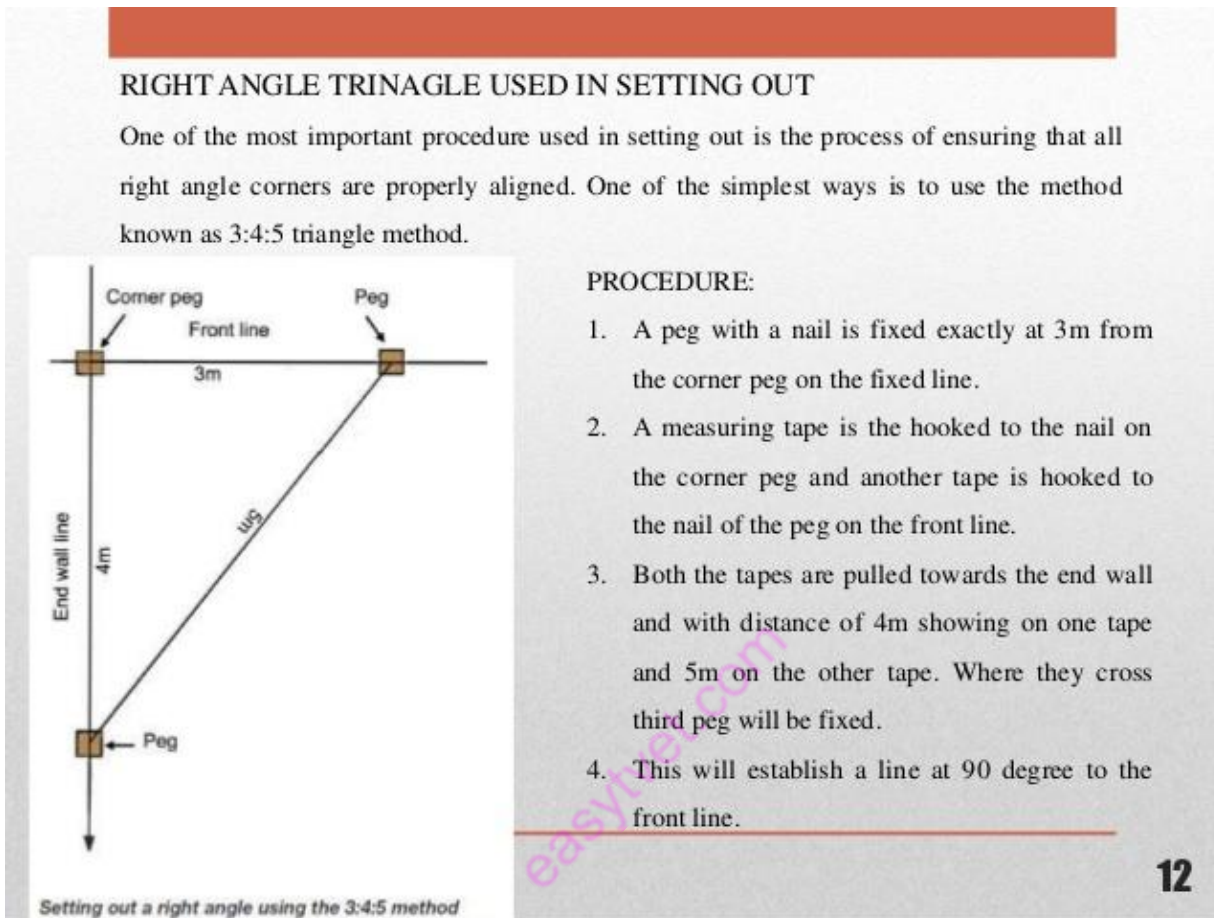

Figure 10: a picture of illustration of setting out using Right angle method Adopted from: [hpdconsult.com](http://hpdconsult.com)

- **Builder's Square Method-**

This is similar to the 3-4-5 method, but in this case instead of using a tape a steel builder's square or a large timber square and a line are used to establish the squareness of the corners. Two pegs (P1, P2) with nails at their tops are driven along the building line. One at the corner. A line is then held along the two pegs tied at P1 going round the corner peg P2, the building's square is then held with its external angle point at nail of the corner peg, while the line on P1, P2 is touching one entire side of the square. This line is then pulled round P2 to touch the other entire side of the builder's square. Holding the line firm a third peg is the driven down where the line touches the top of nail of P3.

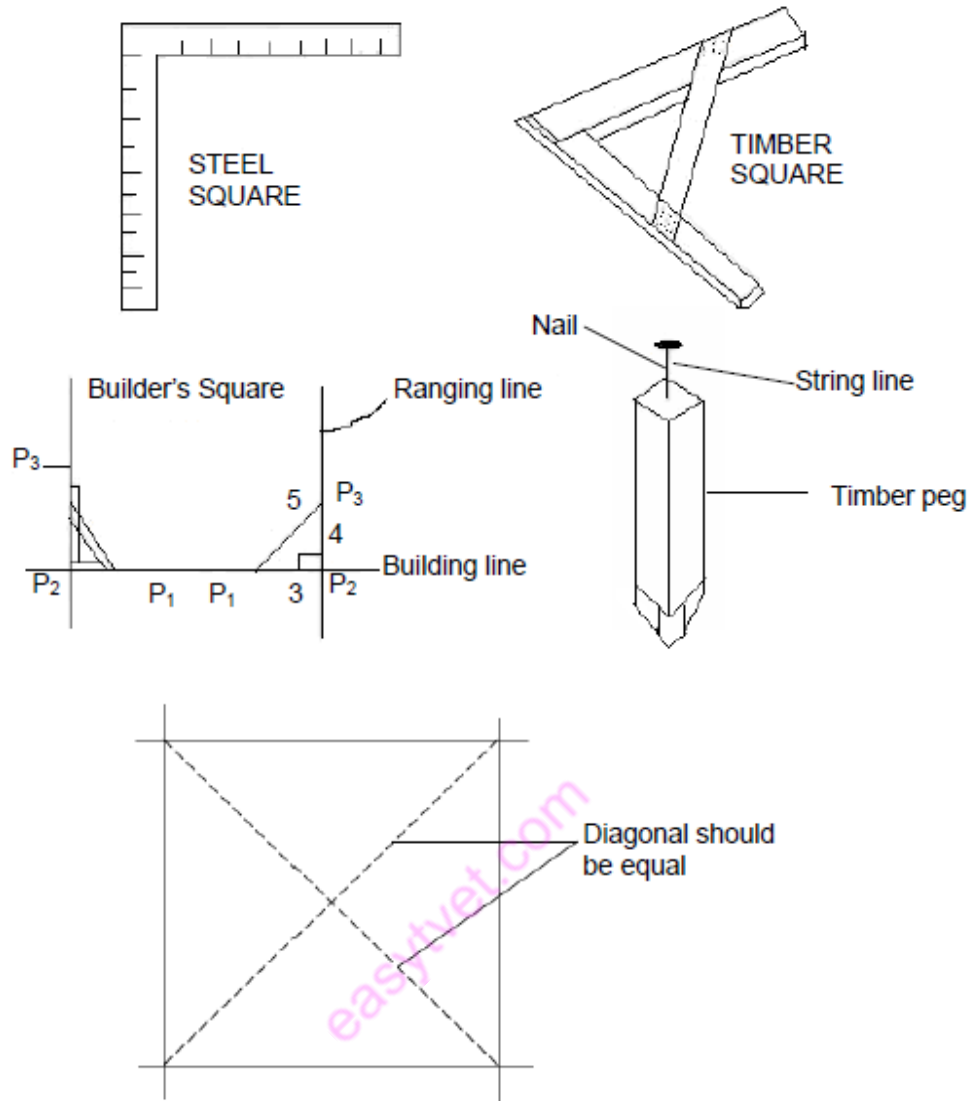

Figure11: a picture of an illustration of setting out using builder's square adopted from: [hpdconsult.com](http://hpdconsult.com)

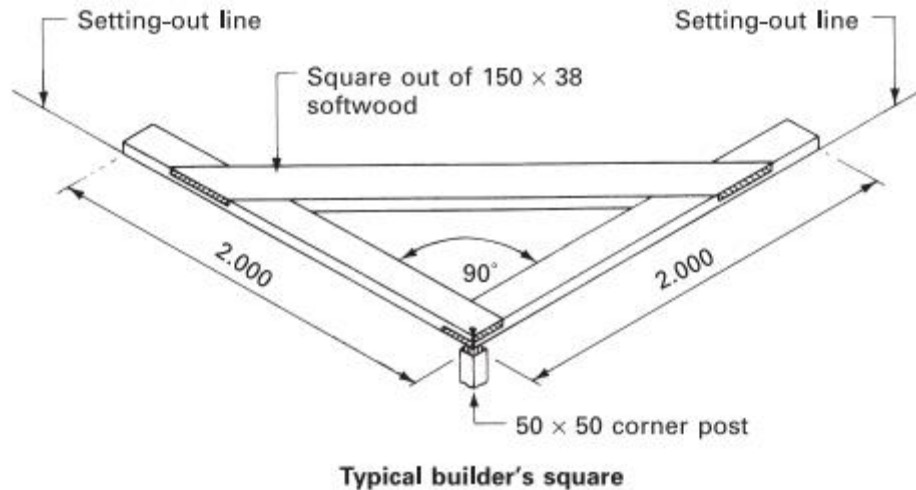

Figure12: A picture of an illustration if setting out using builders square adopted from: [metreumerificateur.wordpress.com](http://metreumerificateur.wordpress.com)

- **Theodolite Method-**

This is the most accurate method of setting out of buildings. It involves using a surveying instrument called the Theodolite. The theodolite is equipped with a telescope and cross hair for sighting and ranging, with internal graduated readings in degrees for establishing bearings (horizontal and vertical angles). The method is as follows

- i. Mount and set the instrument at point A, sight the telescope, range and peg out E and B to establish the building line.
- ii. Turn the theodolite screws and adjust the degree readings to 0.00. Turn the telescope of the instrument on the tripod stand towards the right axis until you can sight 900 00" wide. The instrument clamp sight the telescope and range to established and peg out points F and C.
- iii. Transfer the instrument to point C, and follow the same procedure at A, range A and F, set the angle 0.00", turn towards the right axis to sight and obtain 900 and to establish points G and D.
- iv. Point H could be established by using a measuring tape.

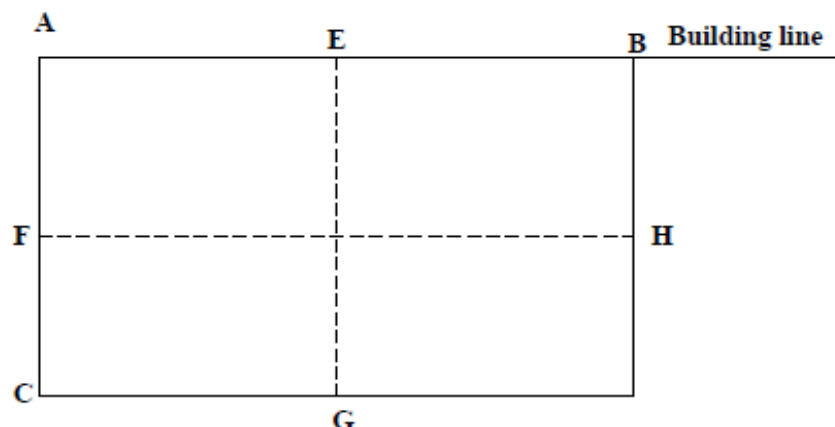

Figure13: an illustration of setting out using theodolite method.

### 1.2.3.2 Types of foundations

#### **What is a foundation ?**

Foundation is the lowest part of the building or the civil structure that is in direct contact with the soil which transfers loads from the structure to the soil safely.

There are four principal types of foundation (i) strip,(ii) pad, and (iii)raft and(iv) pile foundations.

- **Strip Foundation**

This type of foundation is a continuous level support for load bearing walls. It is usually made of a continuous strip of concrete of 1-3-6 mix, and may be reinforced (1-2-6) mix for poor subsoil or high loading. The continuous strip serves as a level base on which the wall is built and should be of such width as to spread the load on the foundation to an area of subsoil capable of supporting the load without stress. The width of a concrete strip foundation depends on the bearing capacity of the subsoil, the less the width of the foundation for the same load. The minimum width of a strip foundation is 450mm and least thickness is 150mm. they are suitable for low-rise construction.

easytvvet.com



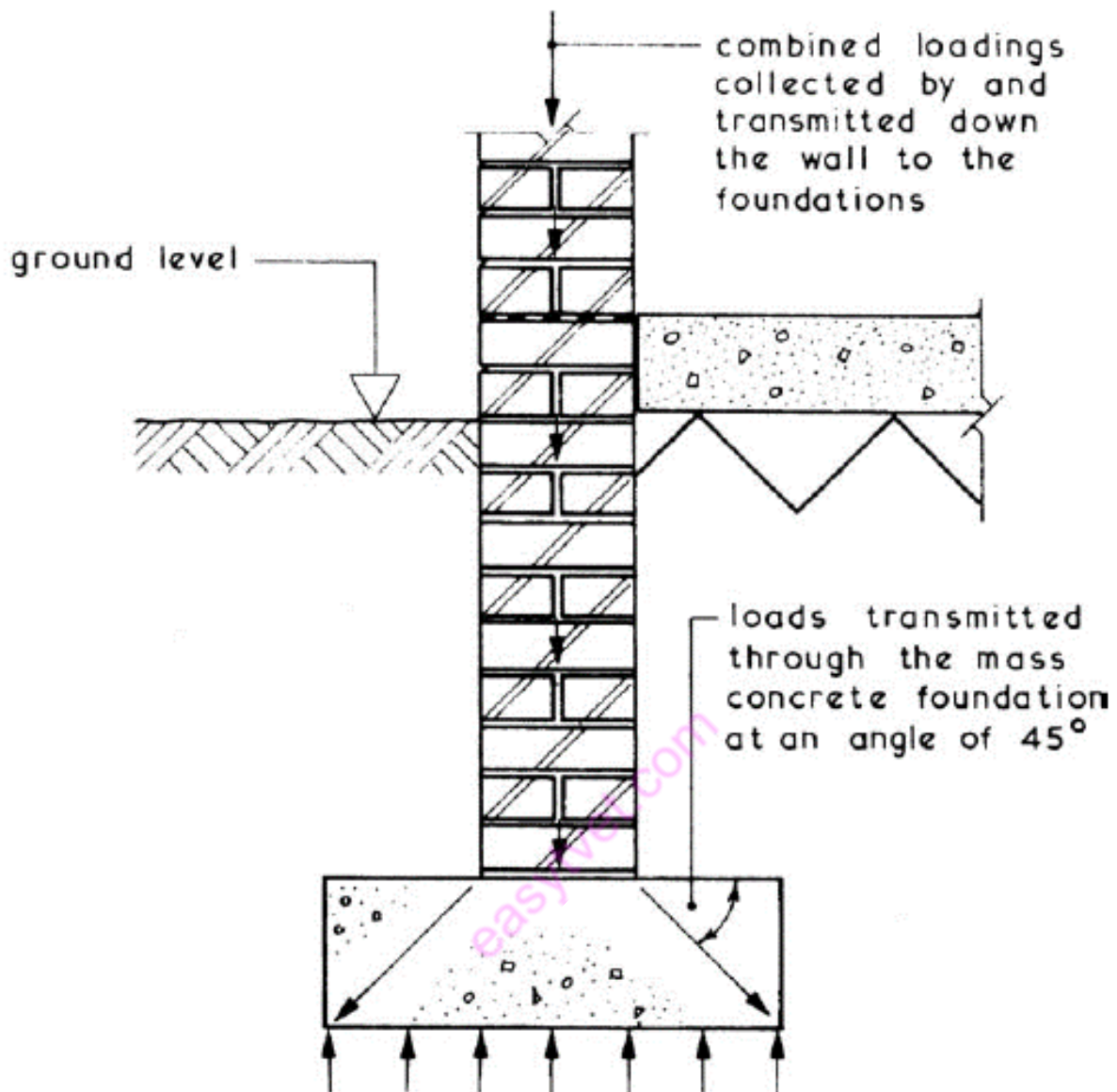
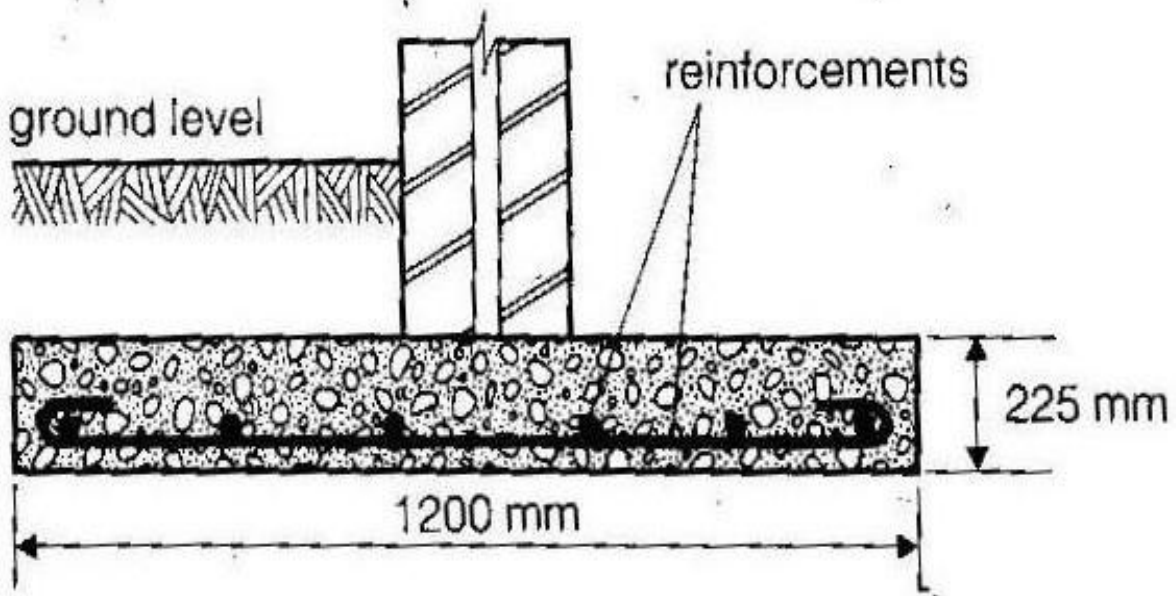

Figure 14: A picture of concrete strip foundation details.  
 Ref. building construction Hand book by chudley page 248

- **Wide Strip Foundation**

This type of foundation is used where the structural loading is very high or relative to the subsoil bearing capacity. It is generally cheaper to reinforce the concrete strip to reduce the equivalent strength thickness to carry and spread the load.

## WIDE STRIP FOUNDATION



c) Wide strip foundation

Figure15: a picture of an illustration of wide strip foundation details.

Ref, <https://waeconline.org.ng/e-learning/Building/Build224nq3.html>

- **Deep strip Foundation**

This type of foundation has two applications Narrow strip or trench fill and Reinforced deep strip The Narrow strip (trench fill)-is designed to save considerable structural construction time and where the nature of the subsoil such as clay requires a considerable depth of 900mm, it is used to excavate foundation trenches and fill them with concrete up to just below the ground level-say 2 brick coarse before the finished ground level.

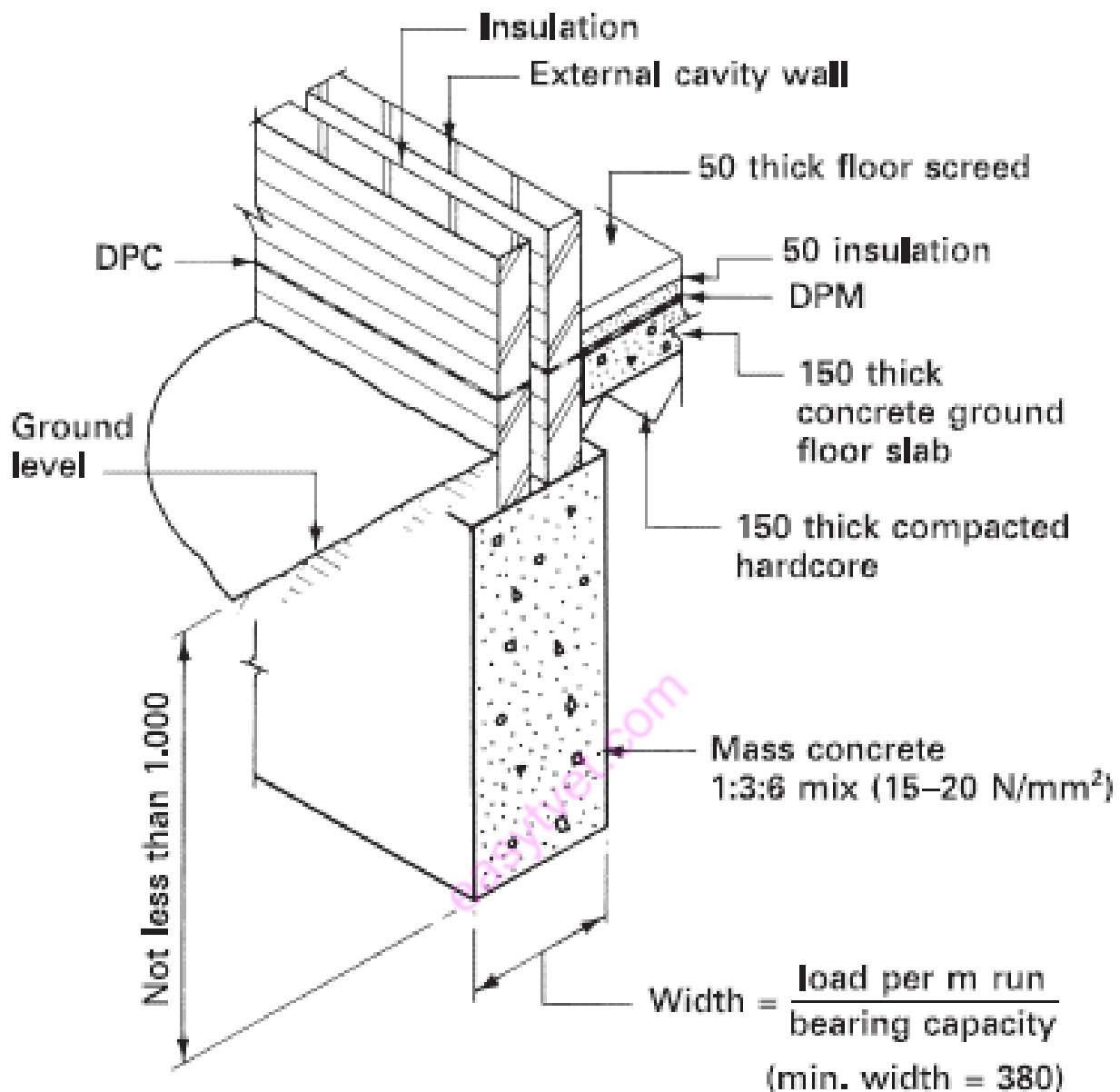

### Deep strip foundation

Figure16: a picture of an illustration of deep strip foundation  
Ref, Construction Technology By Chudley 4 th ed. Page 78

- **Pad Foundation –**

These are isolated pairs or column of brick, masonry or reinforced concrete often in the form of a square or rectangle pad of concrete for supporting ground beams, and in turn supporting walls. It is very economical to use pad foundation where the subsoil has poor bearing capacity for some depth below the surface, rather than excavating deep trenches and raising wall in strip foundations. It is also used where isolated columns are specified, especially in framed buildings. The spread of area of this type of foundation depends on the load on the soil and the bearing capacity of the subsoil.

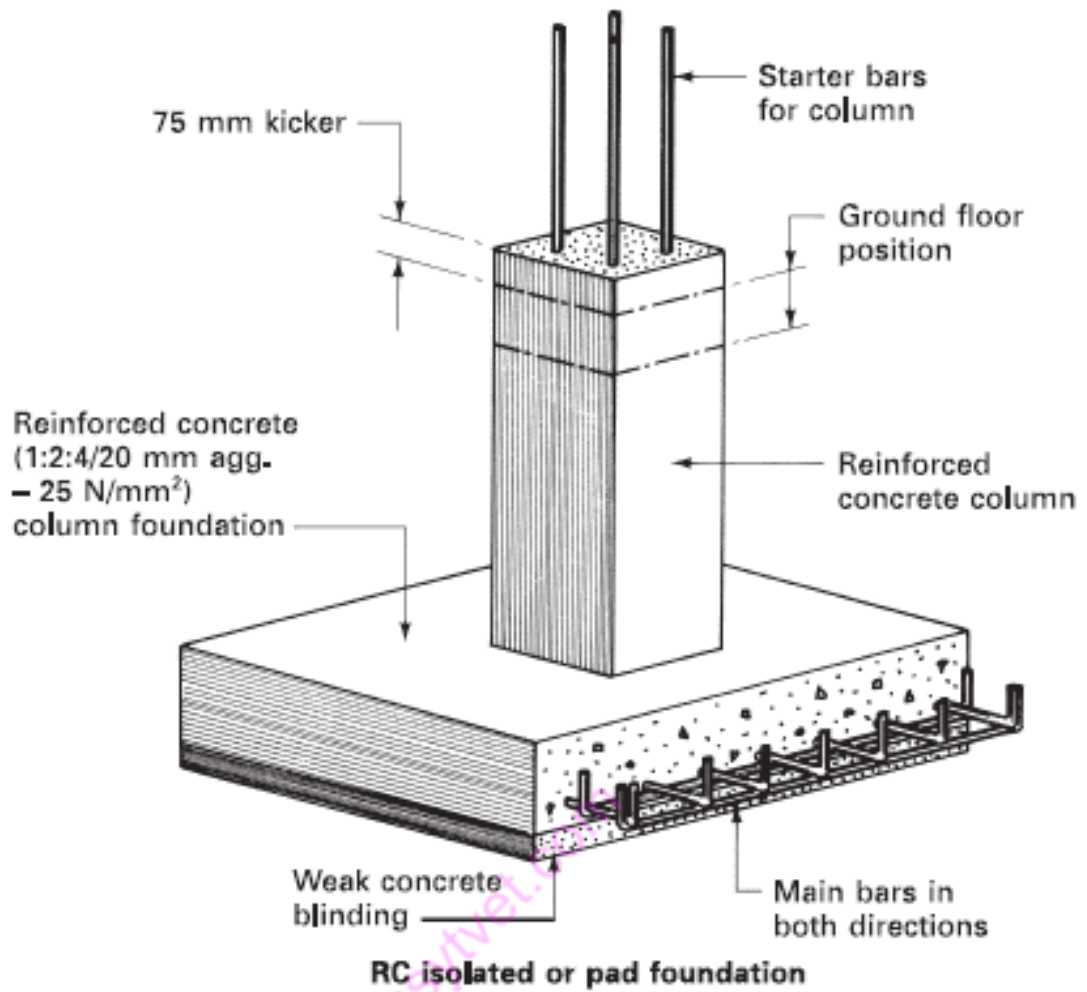

Fig .17 (a) **Reinforced concrete strip and pad foundations.**  
 Ref. Construction Technology 4tyh. Ed. By chudley. Page 80

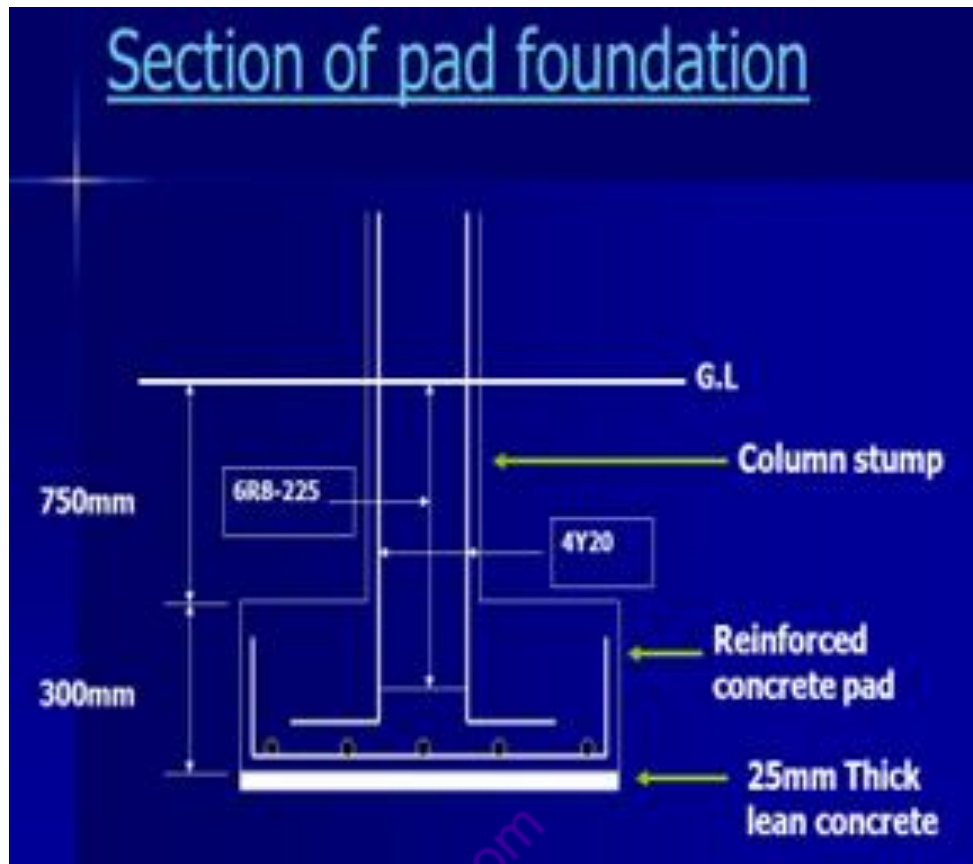

Figure17 (b) : a picture of a Section through pad foundation adopted from: *slideplayer.com*

- **Raft Foundation**

In soft compressible subsoil, such as soft clay or peat subsoil. It is necessary to form a raft foundation to spread over the whole base of the building. Raft foundation consists of a raft of reinforce concrete under the whole of the building design to transmit the load of the building to the subsoil below the raft. Relative settlement between the foundations of columns is avoided by the use of a raft foundation.

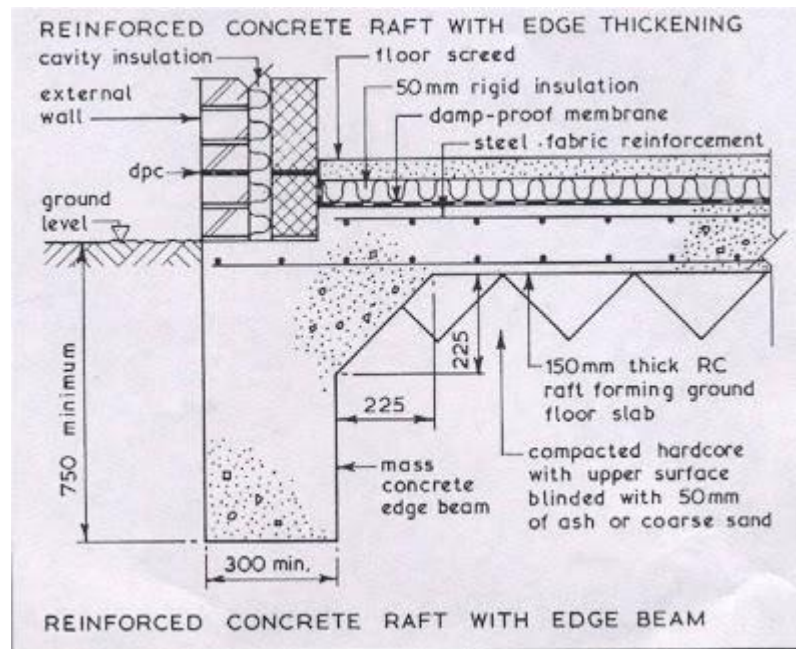

Figure18: a picture of a section of raft foundation adopted from: [architectural guidance.com](http://architecturalguidance.com)

- **Pile Foundation-**

Pile foundations are used where the subsoil has poor and uncertain bearing capacity and in poor drained area where the water table is high and there is appreciable ground movement. Piles are usually employed because in these types of subsoil, it might be necessary to excavate beyond 2m to meet a stable stratum. And it is uneconomical to consider normal excavation beyond about 2m below the ground level. The pile column of concrete either cast in-situ or precast driven into the ground to transfer the loads through the poor bearing soil to a more stable stratum. Boring is undertaken by a powered auger. The pile foundations are normally employed in the construction of bridges and oil platforms on seas.

Short Bored Piles - These are used for small buildings on shrinkage clays where adjacent trees could appreciate volume change in the subsoil. Short bored (short length) piles are cast in holes by hand or machine auger. The piles support reinforced concrete ground beams on which wall are raised.



## Typical Details ~

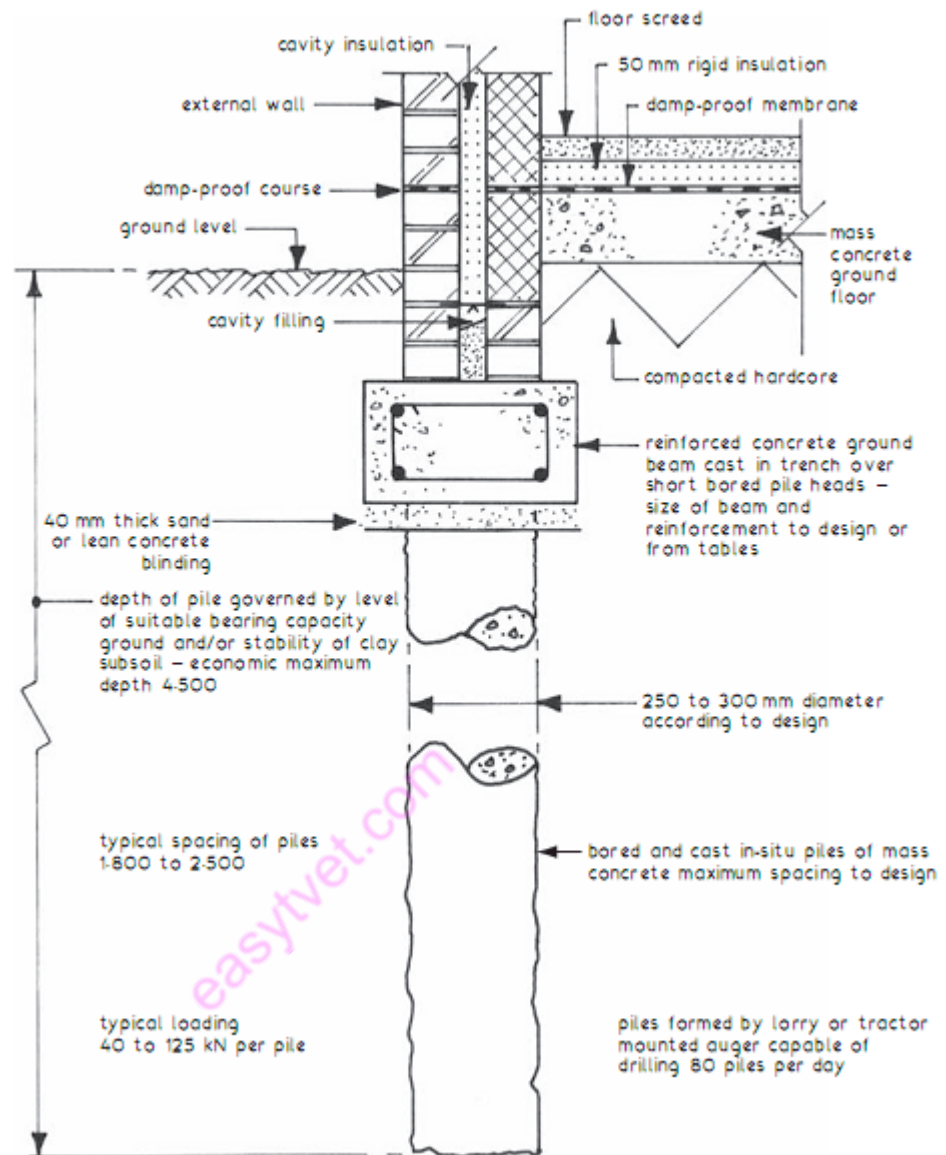

Figure19: a picture of a Section through pile foundation adopted from: [buildersengineers.com](http://buildersengineers.com)

### 1.2.1.4 Learning Activities

#### 1.2.1.4.1 Practical activities

The trainee is expected to interpret building drawing as per the working drawing.

#### 1.2.1.4.2 Field/visit to construction site

Visit objective/Aim	Indicators	Special instruction
To establish taking off ground	Procedure followed during taking off, measurement and making of wall and	As The Working Drawings.



measurements, making walls and columns positions, erecting and making of profile boards and determining accuracy of setting out.	columns, erection of profile boards and determination of accuracy of setting out.	As per architectural and structural details. As per the plans.
--	---	---

**Table 1.3: field visit objectives, indications and instructions on -Foundation taking off, measuring and making off wall positions, erection and making of profile boards and determination of accuracy of setting out.**

#### 1.2.1.5 Self-Assessment

1. What are the considerations that a contractor put in mind during pre- site visit?
2. Where do we consider using pile foundation?
3. Why do we remove topsoil to a depth 150mm before setting out is done?
4. Why do we fence a construction site?
5. Why do site investigation before establishment of a construction site?
6. Why do we do soil testing before establishment of a construction site?
7. What are the requirements of a building foundation?

#### 1.2.1.6 Tools, Equipment, Supplies and Materials

Tools	Measuring tools:- tape measure Surveying tools:- pegs,theodolite Masonry tools:- club hammer,Nails,builders square
Equipment	Laptops Desktop PCs Masonry equipment
Supplies and materials	Personal protective equipment (PPEs) Working drawing Printer/plotting device Calculator Internet Timber/steel boards and nails
Resource	A functioning construction site. Building Code (BS 8110 & BS 449)

**Table 1.4: Tools, equipment, supplies and materials for- Foundation taking off, measuring and making off wall positions, erection and making of profile boards and determination of accuracy of setting out.**

#### 1.2.1.7 References

Rangwala, S.(Ed)(2009)*Building construction*.

Frank, C. (Ed)(1975)*Building Construction illustrated*.

Roy, C. (Ed) (1973) *Construction Technology*.

Roy C ,Roger G (4<sup>th</sup> Ed) (2005) *Construction Technology*.

Edward, A.(Ed) (1985) *Fundamentals of Building Construction Materials and Method*.

Stephen, C. (Ed) (2006) *Barry's advanced construction of buildings*

#### 1.2.1.8 Responses to Self-Assessment

1. What are the factors to be considered by a contractor during pre- site visit?
  - **Availability and means of access to the site whether by road, rail or waterway.**
  - **Availability of suitable materials/equipment and spare available for erecting plant and or storing materials around the site.**
  - **Availability of space to erect temporary site offices and welfare facilities.**
  - **The effect of vibration on adjacent structure when the construction involves using heavy/massive equipment (e.g. in piling) should be considered.**
  - **The availability of water and power supply should be ascertained and the rate of payment investigated.**
  - **Knowledge of the nature and type of soil, and the level of water table are important as the way necessitate subsoil drainage and cause flooding.**
  - **The local planning authorities should be approached to ascertain whether there is any special or significant restriction which could adversely affect the development of site (e.g. underground cables).**
  - **Valuable information can be obtained by talking with the local inhabitants of the area.**
  - **Any special condition that may limit work in anyway should be noted and taken care of e.g. weather or climatic condition.**
2. Where do we consider using pile foundation?

- **Pile foundations are used where the subsoil has poor and uncertain bearing capacity and in poor drained area where the water table is high and there is appreciable ground movement**
3. Why do we remove top soil to a depth of 150mm before setting out is done?
    - **The organic content of the vegetable soil may be injurious to concrete, and so it should never be used for backfilling, or making up levels under the building. The path of excavation of topsoil is normally 150mm.**
  4. Why do we fence a construction site?
    - **To control theft**
    - **To prevent accident**
    - **To control pass by**
    - **For easy supervision**
  5. Why do site investigation before establishment of a construction site?
    - **Geotechnical site investigation performed in order to characterize soil, rock and groundwater condition of the proposed site. A geotechnical site investigation is the process of collecting information and evaluating the conditions of the site for the purpose of designing and constructing the foundation for a structure, such as a building, plant, road, parking lot or bridge.**
  6. Why do we soil testing before establishment of a construction site?
    - **Soil testing is a vital important task that needs to be done before the site is purchased. The composition of the soil must be known so as to examine the ability to withstand structure and to test the ability to absorb water. The site Engineer will insist that you do all necessary soil testing before commencing any structural task on the soil. If the soil at the site is not suitable for the future project, then there may be no choice but to look for another site which has soil suitable for the project**
  7. What are the requirements of a building foundation?
    - **To safety its objectives, foundation must be designed to satisfy certain requirements as to provide suitable support and stability for the structure.**
    - **To safety sustain and transmit to the combined dead, imposed and wind loads in such a manner as not to cause any settlement or other movement which would impair (weaken) the stability or cause damage which or any part of the building or any adjoining building.**
    - **It must be taken down to such a depth as to safeguard the building against the swelling shrinkage and or freezing of the subsoil (especially on clay soil).**
    - **It must be constructed to be capable of resisting any sulphates attack and any deteriorate (harmful) matter present in the subsoil.**

## **2.2 Learning Outcome 2: Excavate building foundation**

### **2.2.1 Introduction to the learning outcome**

The trainee is expected to excavate foundation as per the working drawings, do foundation timbering as per soil analysis report and carry out dewatering as per the dewatering method.

### **2.2.2 Performance Standard**

2.1 Foundation is excavated as per working drawings

2.2 Foundation timbering is done as per soil analysis report

2.3 Dewatering is carried out as per dewatering method

### **2.2.3 Information Sheet**

#### **2.2.3.1 Procedures of construction of various types of foundation**

- **Strip Foundations-**

Construction of strip foundation is carried out by first excavating the ground to specified volume to remove soil to receive concrete. A fairly dry weak concrete is placed to specified depth inside the foundation already containing a hardcore base (if necessary). This is to act as a working base and to receive the over site concrete. Where a reinforcement or mesh is required, they are placed on mortar blocks or concrete blocks (biscuit) on the blinding to give the cover for concrete. A leveling instrument or a building plumb and short iron pegs (off cuts) are then used to establish the tip level of the concreting in the trench at intervals throughout the length of the foundation trench. Concrete is then mixed and is poured into the trench over the reinforcement until it reaches the established pegs. As pouring is done a potter vibrator is used to vibrate the concrete to remove the voids from the concrete. The concrete is then left to set and harden and cured with water after one day of easting for at least 7 days.

- **Pad Foundation-**

This is similar to the strip foundation construction, except that instead of excavating in strips, deep hollow square or rectangular trenches are dug. The provision of reinforcement for the base of the pad interlocks with the vertical reinforcement going up for the columns. This is to ascertain a continuous interlocking support, strength and stability between the pad and the concrete column. Where steel stanchions (columns) would be placed on the pad foundation, steel/iron bolts or steel plates are embedded in the foundation during construction, where the stanchions or columns would be placed (bolted or welded) on the pad foundations. Concrete is then mixed, poured or placed, vibrated and cured as in the strip method. In some cases formwork are sometimes used to protect the sides and give shape to the pad.

- **Raft Foundation –**

The raft system involves the excavation of the whole base area of the building and where ground beams are specified, is further excavated below the raft slab foundation. Formwork is made to support the sides of the foundation and in-situ slab. The placing of reinforcement for the slab and beam interlock or overlaps. The placing of concrete and curing is as in the

strip method. The placing of reinforcement for the slab and beam interlock or overlaps. The placing of concrete and curing is as in the strip method.

- **Pile Foundation-**

This is a kind of deep foundation, is actually a slender column or long cylinder made of materials such as concrete or steel which are used to support the structure and transfer the load at desired depth either by end bearing or skin friction.

A foundation is described as 'piled' when its depth is more than three times its breadth.

- a. **Bored Piles-**

This method is an in-situ concrete construction. It consists of drilling or boring a hole by means of earth drills or mechanically operated augers which withdraws soil from the hole for casting of pile in position. Usually steel lining tubes are lowered or knocked in as the soil is taken out, to support the sides of the bored pile.

Reinforcement are placed, concrete is then placed and compacted in stages. As the concrete pile is cast the lining tubes are gradually withdrawn the disadvantages of this method are that it is not possible to check if the concrete is adequately compacted, and there may be no adequate cover to the concrete reinforcements. (see fig.20 below)

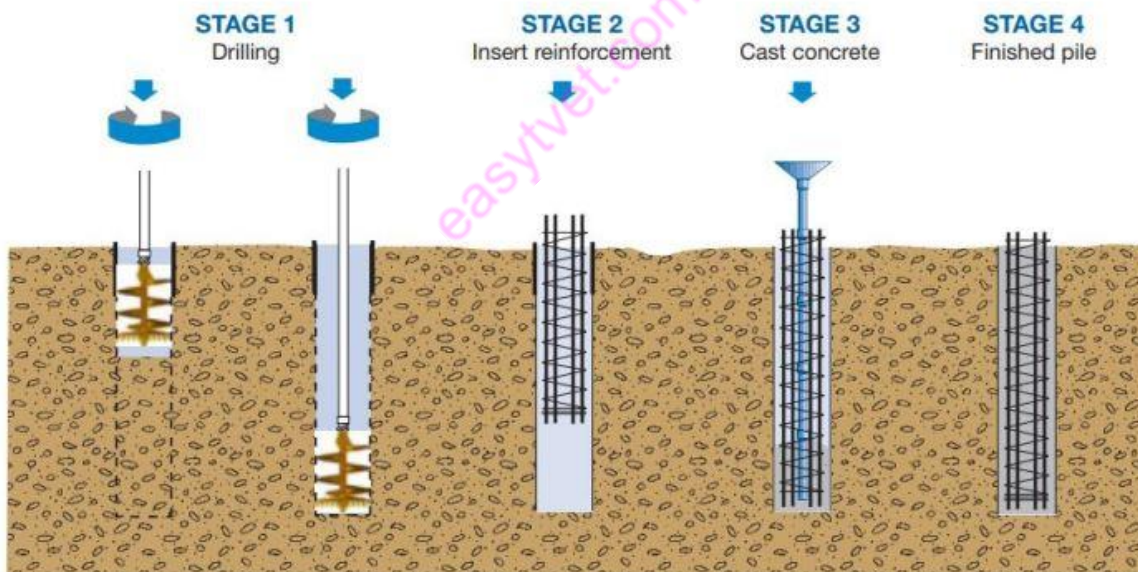

Fig. 20. Stages in Bored Pile Construction

Ref. <https://theconstructor.org/geotechnical/bored-pile-foundation/84417/>

- b. **Precast Concrete Piles-**

As the name implies, these are precast either round, polygonal or square concrete, steel or timber piles which are driven into the ground by means of a mechanically operated drop hammer attached to a mobile piling at a calculated predetermined „set“. The word „set“ is used to describe the distance that a pile is driven into the ground by the force of the hammer. To concrete the top of the precast piles to the



reinforced concrete foundation at the top, 300mm of the length of reinforcement of the pile is exposed, to which the reinforcements of the foundation is connected. ( se fig 21 below)

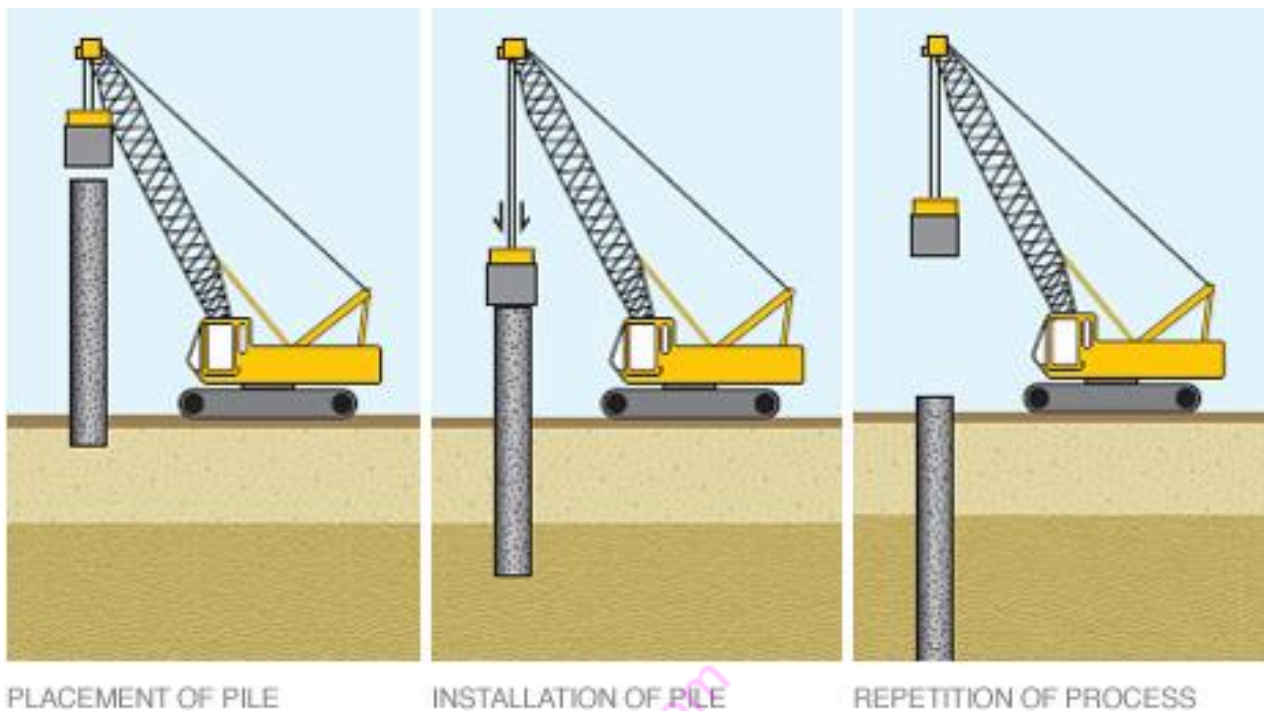

Fig 21. Precast ( Driven) Pile installing method

Ref. <http://basiccivilengineering.com/2016/11/type-of-pile-foundation-in-construction.html>

### 2.2.3.2 Excavation-

Excavation in building construction is simply the act of removing or digging out earth (soil) from the ground for the purpose of laying foundation, construction of floor, basements, etc. The earth is originally dug up to specified depth, width and length.

The technique of excavation is largely determined by sensitivity of the site to vibration, intensity of work, availability of plant and the subsoil composition. The technique of excavation is largely determined by sensitivity of the site to vibration, intensity of work, availability of plant and the subsoil composition. There are basically two methods of excavation, the manual method and the mechanical method

- **Manual method-**

This involves the use of hand tools such as spades diggers, hand augers, pickers (rakes) and other manual implements for the purpose of excavation. The manual method is regarded as a cheap means of excavation, it is virtually obsolete and time consuming. The method can be used only in very small buildings, e.g. garages or house extension, where the site is inaccessible to excavating plant, and where archeological remains are discovered and particular care is necessary. The method is also used for trimming excavations by mechanically means where outward projections and deviations are specified.

- **The mechanical method-**

This is a process of using mechanical plant and equipment for excavation. This use of mechanical plant and equipment saves considerable man-hours, and are standard features on all sites. The type of plant varies with the nature of work and the different construction stages. Plant can commonly be used for:

- a. Striping clearance and light demolition
- b. Striping of top soil
- c. Trench excavation
- d. Basement excavation

### 2.2.3.3 Types of plant machine used for excavation

#### a) **Bulldozer**

Bulldozers are track or wheel-mounted with a forward-facing mould blade controlled by hydraulic rams. The blade is capable of tilting about a central swivel point, allowing for a dipping depth of 300 mm. This means they are commonly used for stripping sites, reduced level digging and pushing earth from one point to another.

Bulldozers are also used for clearing vegetation and small trees, acting as a towing tractor and can be adapted as an angledozer which pushes and casts spoil to one side of the mould blade, avoiding side spillage when pushing material forward.



Figure22: a picture of a bulldozer Adopted from: *though.com*



**b) Motor grader**

Motor grader is one of the most important machines used in construction and maintenance of roads and for making smoother surfaces, fine grade, levelling soil and shifting small amounts of dirt.



*Fig. 23 Motor grader-earth leveling*

Ref. <https://www.komatsu.eu/en/motor-graders/gd675-6>

**c) Loader/Backhoe (Backacter) –**

The backacter/loader has on one end a toothed bucket and hydraulic boom which extend out and excavate towards the cab. This end is used mainly for excavation of trenches, basement and ditches. The other is equipped with a face shovel loader for loading excavated loose earth into a dumper, a tipper or lorry.



Figure24: A picture of a backactor Adopted from: bullindia.com

**d) Scrapper –**

The scrapper contains a larger bowl with covered cutting edge for stripping soil. It is used in very large sties, airfield of highway.



Figure25: a picture of a scrapper Adopted from: *stateplanhire .com*

e) **Dragline/Grab Crane –**

Where the volume of excavation is large, the crane- mounted dragline is preferred. The bucket is swinging forward to penetrate the subsoil and dragged back towards the cab. Deep excavation into granular soils is more effective with a grab or „clamshell“.



shutterstock.com • 1011339790

Figure26: a picture of a grab crane Adopted from: *shutterstock.com*

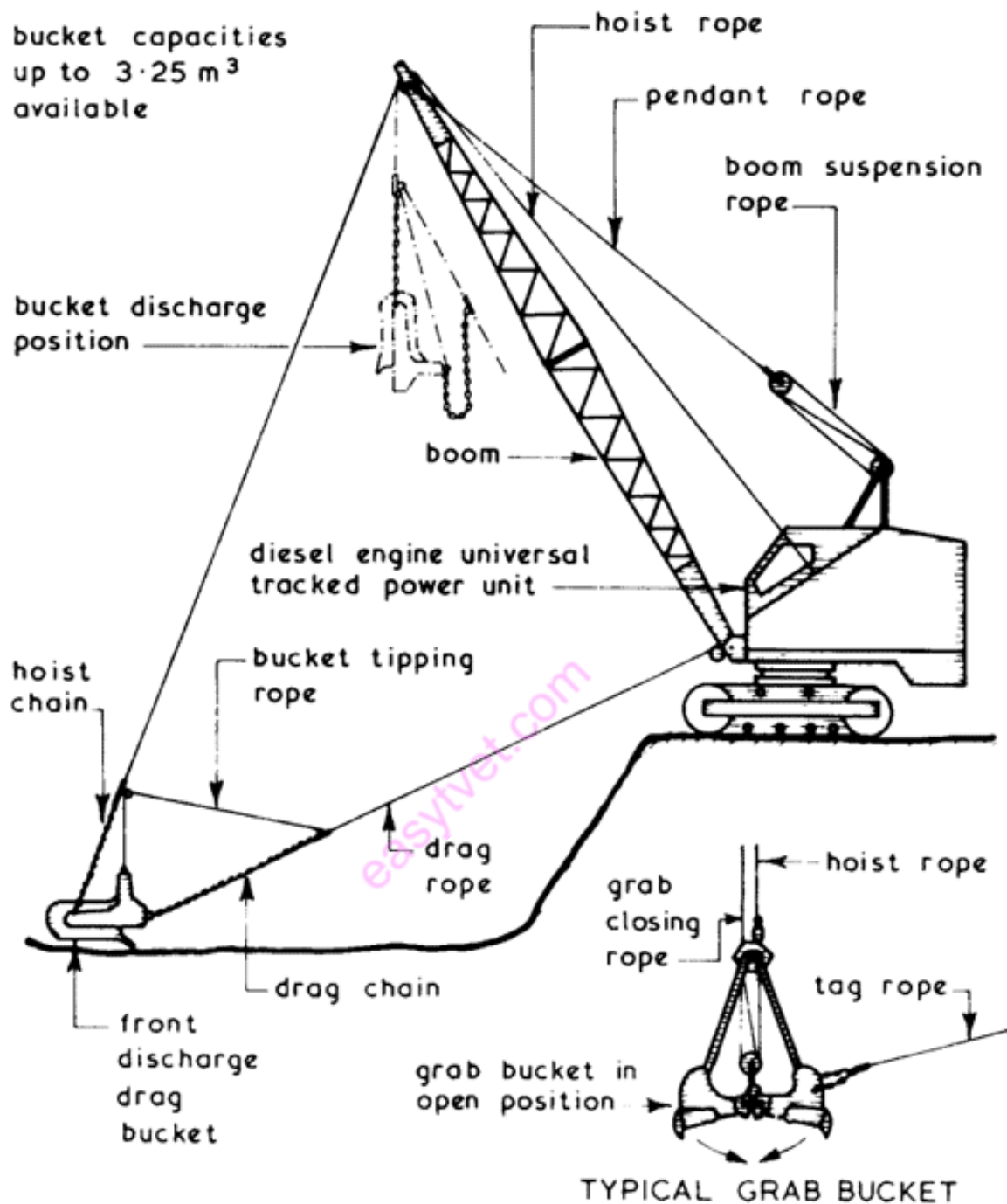

Fig. 27 Typical dragline Details

Ref. <http://www.buildersengineer.info/2014/05/draglines-construction-machinery.html>

#### 2.2.3.4 Earthwork Support-

When excavations (trench) are dug in water saturated soils, it is important to provide supports to the side of the excavation. This is done to prevent the walls from caving-in (collapse) causing severe injury or death to those required to work inside the trench. Apart from causing injury and death, it will be additional cost to the builder to re-excavate and renew the damaged work in the trench. Should the sides support

collapse, timber and steel are normally used for trench. The process of supporting trenches is generally termed “Timbering and strutting”. The amount of support, side and system of arrangement of the various timbers depends on:

- f) The type and nature of subsoil to be supported.
- g) The depth of excavation.
- h) The length of time the trench is to remain open.
- i) The time of year or climatic conditions prevailing when the trench is excavated.

Timber is often the most convenient material for shallow trenches. Steel interlocking polings are often used for deep water-logged subsoil. Adjustable steel struts are also more convenient and have considerable re-use value for all depths of excavation.

The purpose of supporting the sides of trenches (excavation).

- To uphold the sides of excavation to avoid collapse of the sides
- To protect the operations while in the excavations.
- To avoid the wasteful labour of constantly clearing falling earth from the excavation bottoms.

The timbering members used in trench support are as follows:

- i. **Poling board** –  
There are of 1.0 to 1.5m in length to suit the trench depth, and they vary in cross-section from 175 by 35mm to 225 by 50mm. They are placed vertically and against the soil of all the sides of excavation.
- ii. **Wallings** –  
These are longitudinal members running the length of the trench and supporting the poling boards. They vary in sizes from 175 by 50mm to 225 by 75mm.
- iii. **Struts** –  
These are usually squared timbers, either 100 by 100mm or 150 by 150mm in sizes. They are used to support the walling's, which in turn holds the poling boards in position. Adjustable steel struts are also in great use.
- iv. **Sheeting** –  
These consist of horizontal boards abutting one another to provide continuous barrier when excavating in loose soils and common size for the sheeting is 175 x 75mm and there is overlap of about 150mm at the point of connection between two stages. Alternatively, steel interlocking poling with adjustable steep struts are used.

## 2.2.3.5 Timbering to Trenches

### 2.2.3.5.1 Timbering in loose subsoil-

- **Box sheeting method**

This method is adopted in loose soils, when the depth of excavation does not exceed 4 metres. {**vertical sheeting Fig. 28 (a)**} shows the box like structure, consisting of vertical sheets placed very near to each other (some times touching each other) and keeping them in position by longitudinal rows (usually two) of wales. Struts are then provided across the wales.

Another system of box sheeting, shown in {**horizontal sheeting Fig. 28(b)**}, is adopted for very loose soils. In this system, the sheeting is provided longitudinally, and they are supported by vertical wales and horizontal struts [**Fig. 28(b)(i)**]. If the height is more, braces are also provided along with struts. **Fig. 28(b)(ii)**].

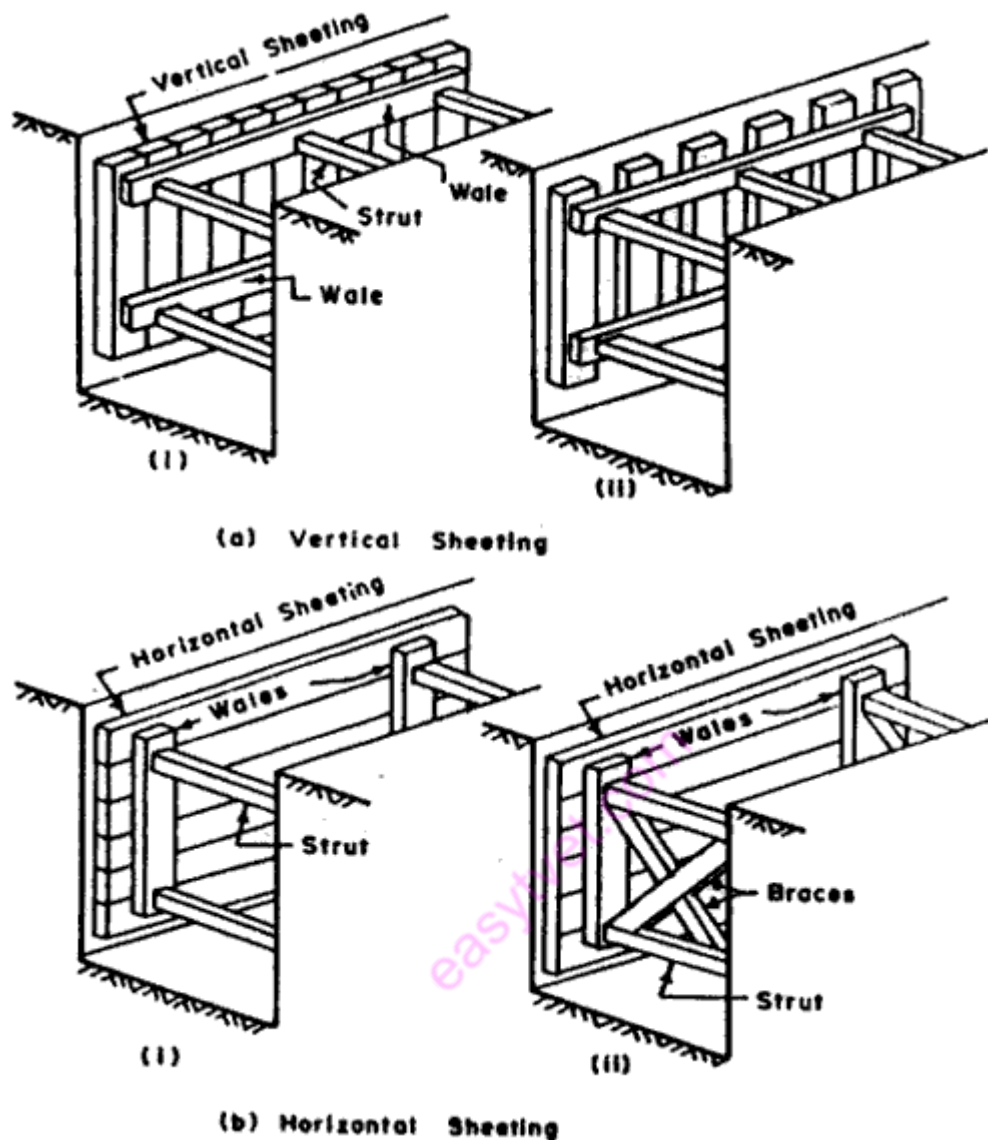

Fig. 28 Box Sheeting

Ref. <http://www.abuildersengineer.com/2012/10/timbering-of-trenches-soils.html>

### 2.2.3.5.2 Timbering in Moderately Firm Soil

- *Stay bracing method*

This method (Fig. 29) is used for supporting the sides or a bench excavated in fairly firm soil, when the depth of excavation does not exceed about 2 metres. The method consists of placing vertical sheets (called sheathing) or polling boards opposite each other against the two walls of the trench and holding them in position by one (Fig. 29)(a) or two rows of struts (Fig. 29)(b). The sheets are placed at an interval of 2 to 4 metres and generally, they extend to the full height of the trench. The polling boards may have width of about 200



mm and thickness of 44 to 50 mm. The struts may have size 100 x 100 mm for trench upto 2 m width and 200 x 200 mm for trench upto 4 m width.

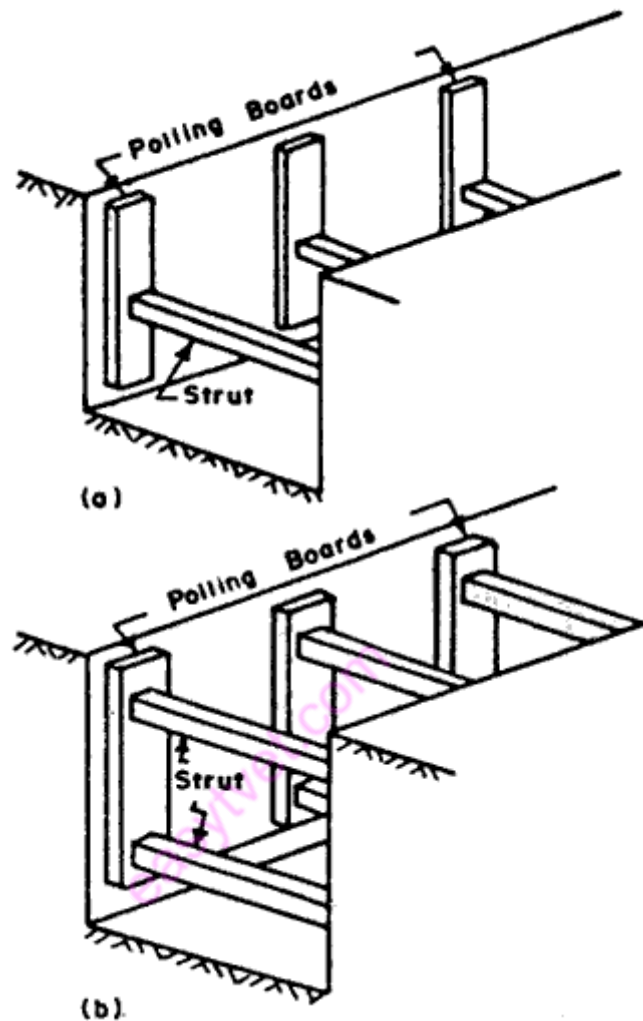

Fig. 29 Stay bracing

Ref. <http://www.abuildersengineer.com/2012/10/timbering-of-trenches-soils.html>

### 2.2.3.5.3 Timbering in soft soil but deep trenches

- *Vertical sheeting method*

This system is adopted for deep trenches (upto 10 m depth) in soft ground. The method is similar to the box sheeting [Fig. 28 (a)] except that the excavation is carried out in stages and at the end of each stage, an offset is provided, so that the width of the trench goes on decreasing as the depth increases. Each stage is limited to about 3 m in height and the offset may vary from 25 to 50 cm per stage. For each stage, separate vertical sheeting, supported by horizontal walings and struts are provided (Fig.30).

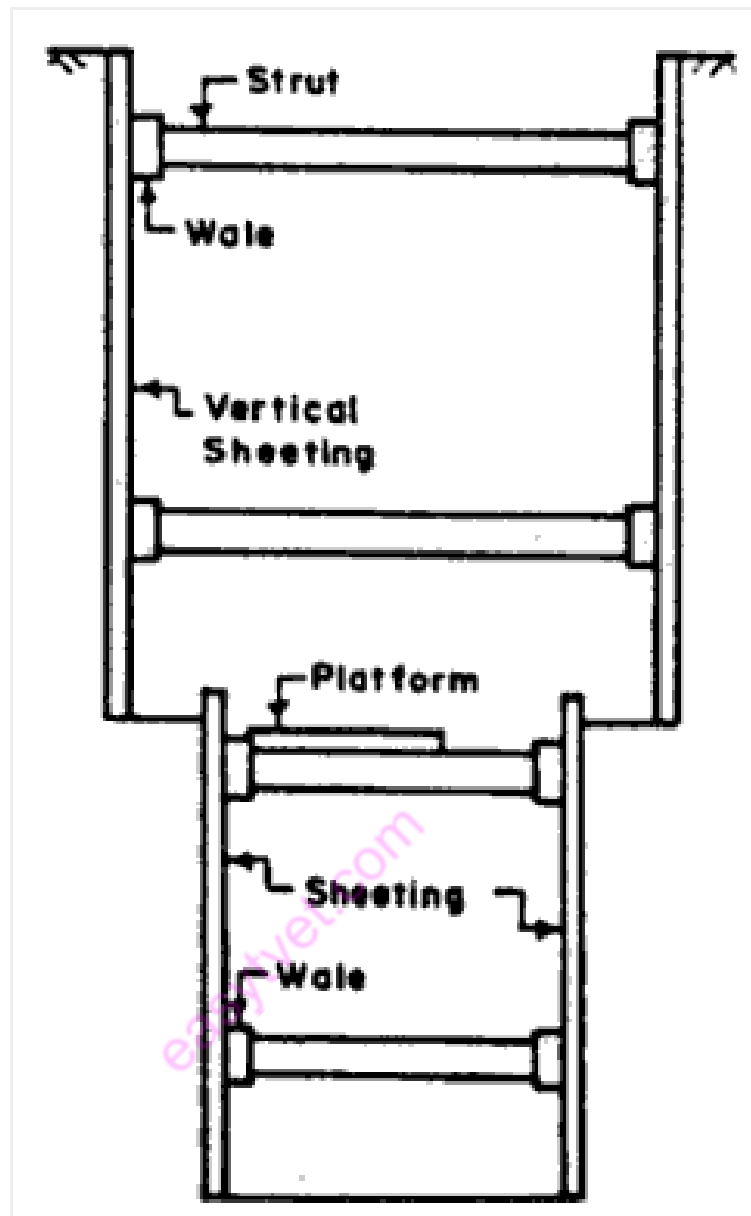

**Fig 30 Vertical Sheeting**

Ref. <http://www.abuildersengineer.com/2012/10/timbering-of-trenches-soils.html>

#### 2.2.3.5.4 Timbering in extremely loose and soft ground

- ***Runner system method***

This system is used in extremely loose and soft ground, which needs immediate support as excavation progresses. The system is similar to vertical sheeting of box system, except that in the place of vertical sheeting, runners, made of long thick wooden sheets or planks with iron shoe at the ends, are provided. Wales and struts are provided as usual (Fig. 31). These runners are driven about 30 cm in advance of the progress of the work, by hammering.



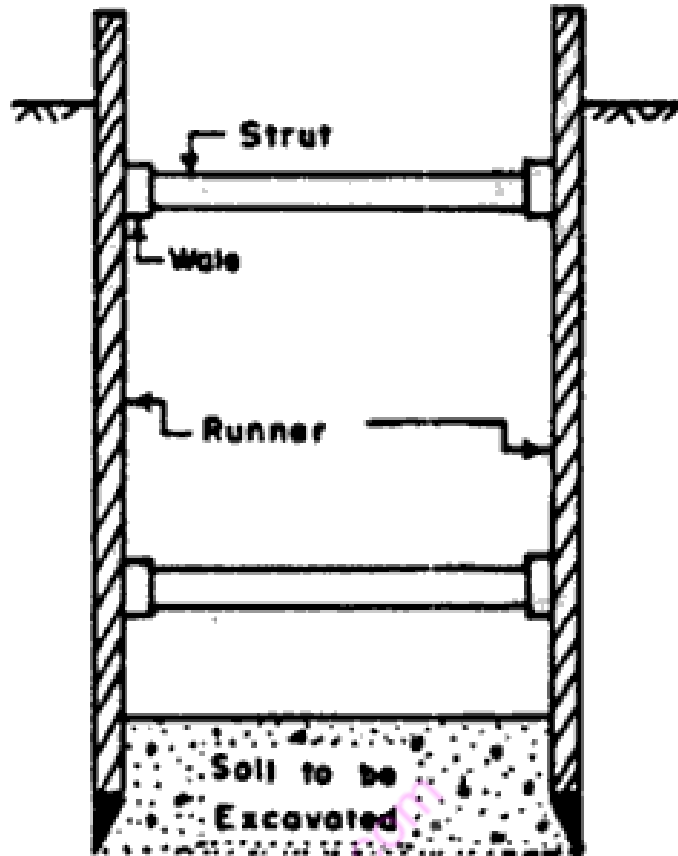

Fig. 31 Running system

Ref. <http://www.abuildersengineer.com/2012/10/timbering-of-trenches-soils.html>

## 2.2.3.6 Control of Ground Water in an Excavation

### ❖ Dewatering-

This is the artificial lowering of ground water in a construction site. It involves temporarily lowering the ground water table to permit excavation and construction within a relatively dry environment.

Presence of ground water affects the stability and bearing capacity of the subsoil. This is occasioned by the water acting as a lubricant to the finer particles of clay soils; enabling them to move when subjected to a load like foundation loading, or

Causing them to flow by movement of ground water this movement creates voids, and hence settlement of the larger particles.

Methods of dewatering

- i. Sump pumping
- ii. Well-points
- iii. Deep wells
- iv. Shallow wells
- v. Horizontal drainage
- vi. Ground freezing
- vii. Electro-osmosis.

- *Sump pumping*

Sump pumping is the process of evacuating that liquid using pumps. it is one of the simplest dewatering techniques: groundwater seeps into the excavation and is allowed to collect in sumps – which can either be the lowest point of the excavation or may be an area specially created into which water may seep naturally e.g a well or sump. Each sump will typically have one or more robust electric-powered pumps with the capacity to handle the solids that will inevitably be present. The collected liquid is then pumped away for disposal, either with pumps running continuously or activated automatically as the water level rises.

For prolonged pumping the sump should be prepared by first driving sheeting around the sump area and installing a cage inside the sump made of wire mesh with internal strutting or a perforating pipe filling the filter material in the space outside the cage and at the bottom of the cage and withdrawing the sheeting. (Fig. 32 (a))

Limited to a maximum depth of 7.5m because of the limitations of the suction lift of the pump.

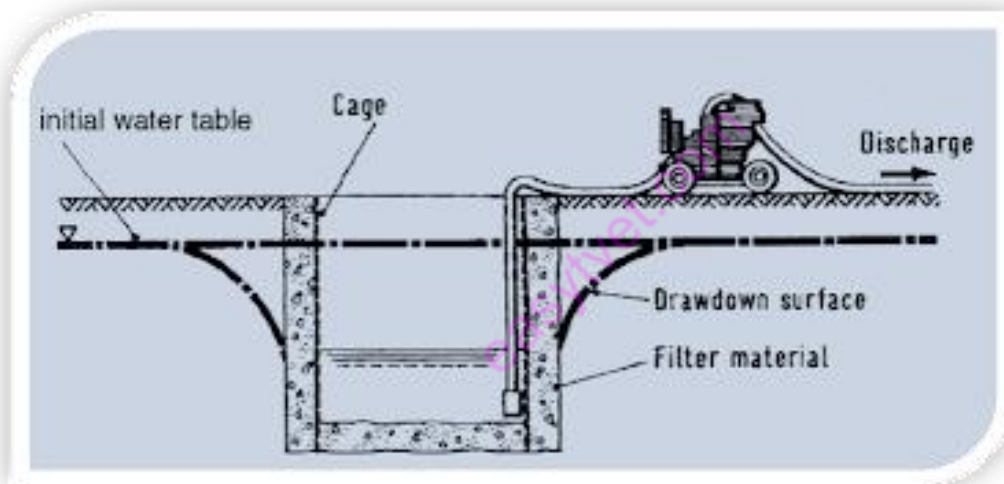

Fig. 32 Sump pumping

Ref. [https://www.engineersdaily.com/2013/11/methods-of-dewatering-of-](https://www.engineersdaily.com/2013/11/methods-of-dewatering-of-foundations.html)

[foundations.html](https://www.engineersdaily.com/2013/11/methods-of-dewatering-of-foundations.html)

- **Well-point System**

A well point is 5.0-7.5 cm diameter metal or plastic pipe 60 cm – 120 cm long which is perforated and covered with a screen. The lower end of the pipe has a driving head with water holes for jetting. Well points are connected to 5.0-7.5 cm diameter pipes known as riser pipes and are inserted into the ground by driving or jetting. The upper ends of the riser pipes lead to a header pipe which, in turn, connected to a pump. The ground water is drawn by the pump into the well points through the header pipe and then discharged. This type of dewatering system is effective in soils constituted primarily of sand fraction.

The well points can lower a water level to a maximum of 5.5 m below the centerline of the header pipe. In silty fine sands this limit is 3-4 m. Multiple stage system of well points are used for lowering water level to a greater depth. A single well point handles between 4 and 0.6 m<sup>3</sup>/hr depending on soil type.

In **Well Point Dewatering System** an **excavated area** dry continuously kept dry by intercepting the flow of groundwater with **pipe wells** driven into the ground. The main components of the well-point system are:

- i. The Well Points
- ii. The Riser Pipe
- iii. The Swinger Arm
- iv. The Header Pipe
- v. The Pumps



Fig. 33 a picture of well point method of dewatering  
Ref. a adopted from: *sldpumpspower.com*

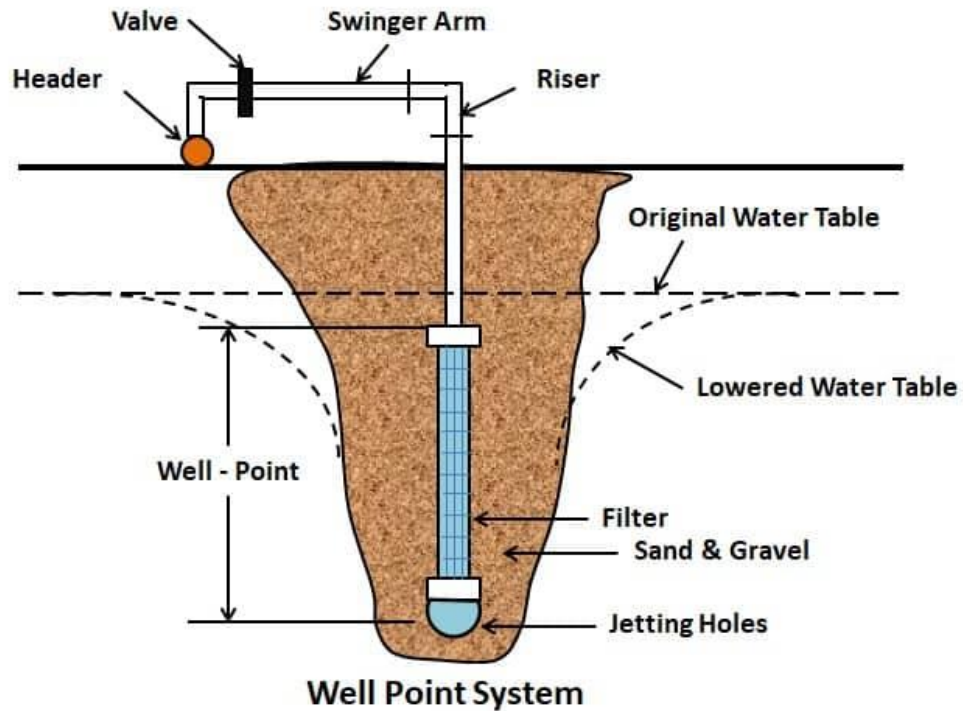

(Fig. 34 Well point system)

Ref. <https://civiconcepts.com/blog/dewatering>

- **Deep wells system**

This system is more suitable when the depth of excavation is more than 16m or where artesian water is present.

In this, a **system of a 15 to 60 cm diameter hole** is bored and a casing with a long screen is provided. A **submersible pump** is installed near the bottom of the well. Each well has its own pump.

Along with the deep wells arranged on the **outer side of the area** under excavation, a row of good points is frequently installed at the toe of the side slopes of the **deep excavation**.

Large-diameter (300-600 mm) holes, drilled relatively deep (greater than 9 meters) are fitted with a slotted liner and an electric submersible pump.

The amount of drawdown that a well can achieve is limited only by the size of the pump.

They work best in soils consisting of sand, or sand and gravel mixtures and can dewater large areas to great depths. (Fig. 2.2.3.6 (d) and (e))

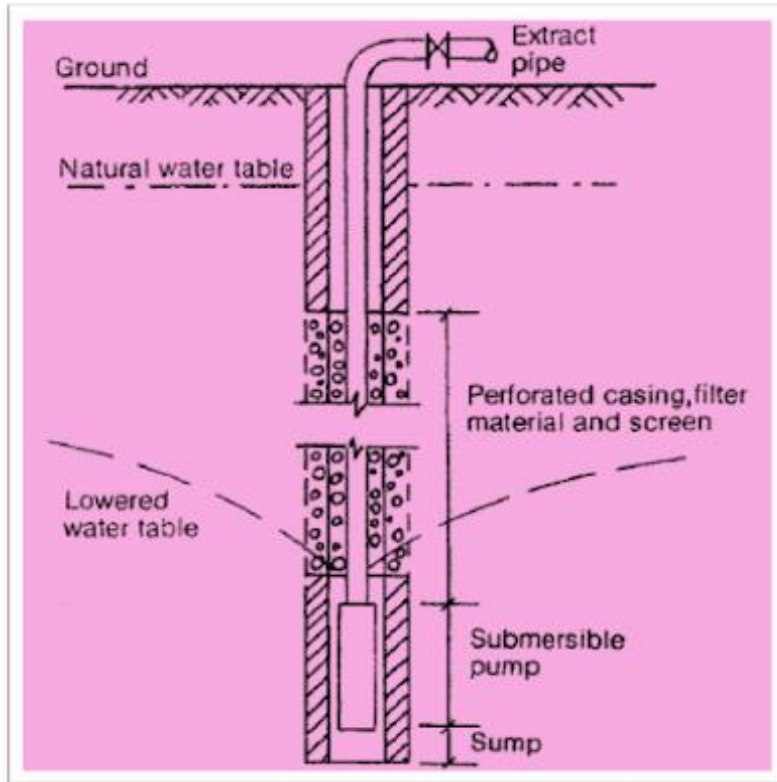

(Fig. 35 Deep well pumping

[Ref.https://www.engineersdaily.com/2013/11/methods-of-dewatering-of-foundations.html](https://www.engineersdaily.com/2013/11/methods-of-dewatering-of-foundations.html)

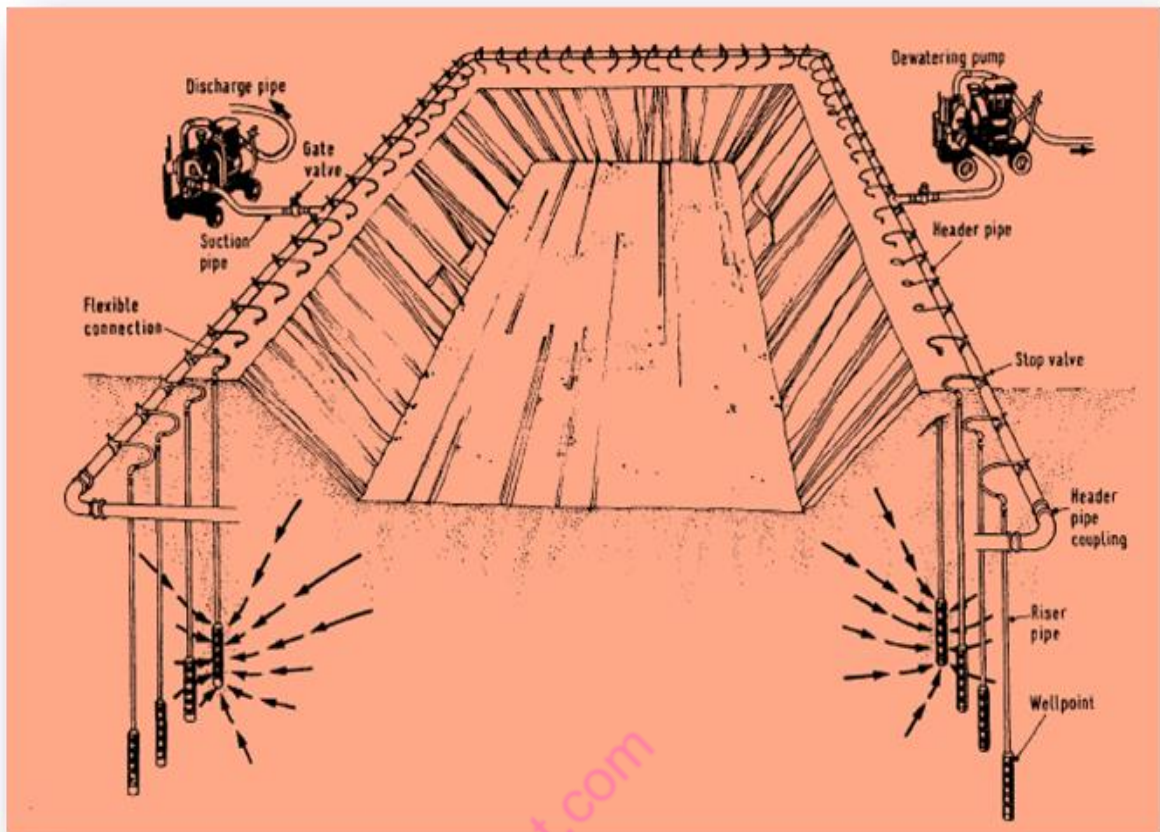

Fig. 36: a picture of a deep well method of dewatering Adopted from: *Engineersdaily.com*

- **Shallow well system**

In a **shallow well system**, a **hole of 30cm in diameter**, or more is bored into the ground to a depth not exceeding 10 m below the **axis of the pump**.

A **strainer tube of 15cm**, the diameter is lowered in the bore-hole having a **casing tube**. A gravel filter is formed around the strainer tube by gradually removing the casing tube and simultaneously pouring the filter material, such as gravel, etc. in the annular space.

A suction pile is lowered into the **filter well** so formed. The **suction pipes** from a number of such wells may be connected to one common header connected to the pumping unit.

Shallow wells comprise surface pumps which draw water through suction pipes installed in bored wells drilled by the most appropriate well drilling and or bored piling equipment. Its limit is 8 m because these are pre bored. These wells are used in very permeable soils when well pointing would be expensive and often at inconveniently close centers. These can extract large quantities of water. (Fig. 37)





Fig. 37 shallow well

Ref. <https://www.engineersdaily.com/2013/11/methods-of-dewatering-of-foundations.html>

- **Horizontal drainage**

- Consists of installing into the ground a 100mm diameter PVC perforated suction pipe covered with a nylon filter sleeve to prevent the infiltration of fine particles
- The pipe is installed using a special machine that excavates a narrow trench, lays a pipe, and backfills the excavation in one operation
- The drain length is determined by the drain diameter, soil-conditions and the water table.
- After installation of the drainpipe a pump is connected to the drain and water can be pumped out. Installation depths:- up to 6 meters



Fig. 38 : a picture of horizontal drainage method of dewatering a doted from: *koopdewatering.com*

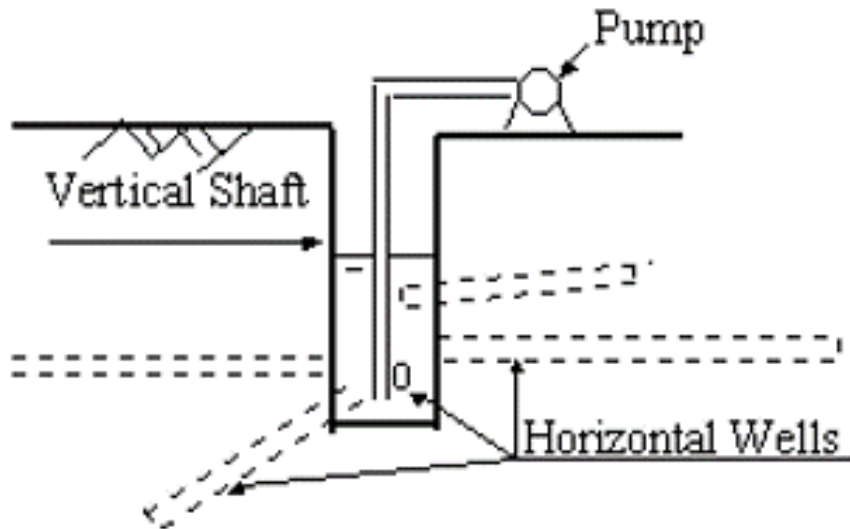

Fig. 39 Dewatering by horizontal well

Ref. <http://osp.mans.edu.eg/soilhydraulics/ch8.htm>

- **Ground Freezing**

This types of dewatering method consist of forming a wall of ice by freezing the soil around the area to be excavated. Freezing pipes encasing smaller diameter inner pipes are Sunk about the one-meter center to center along the periphery of the area to be excavated. The layout of the pipes should preferably be such that the area enclosed is circular in plan.

The freezing liquid is then supplied to the freezing Pipes by refrigeration plant. This makes the ground around the pipes to freeze and form a thick wall of frozen earth around the area to be excavated.

This process can be used up to 30 m depth of excavation. The freezing process is suited for work of comparatively short duration. This is because of the fact that the working expenses are heavy and also the stability of frozen earth is not reliable for a long time.



Fig. 40 Ground freezing

Ref. <https://civiconcepts.com/blog/dewatering>

- The principle of ground freezing is to change the water in the soil into a solid wall of ice by inserting freezing tubes into the ground and circulating a freezing solution around the tubes to form ice in the voids.
- This wall of ice is completely impermeable and gives the soil extra mechanical strength
- The circulation solution can be:
  - a) Brine of magnesium chloride or calcium chloride at a temperature of between -16 and -25°C. (takes 10 to 17 days to form the ice wall)
  - b) Liquid nitrogen- quick freezing but more expensive

**Application:**

1. Groundwater cutoff
2. Earth support
3. Temporary underpinning
4. Stabilization of earth for tunnel excavation
5. Arresting landslides
6. Stabilizing abandoned mineshafts.

**Procedure:**

- i. A row of freeze pipes are placed vertically in the soil and heat energy is removed
- ii. through these pipes
- iii. Isotherms (a line connecting locations with equal temperature) move out from the
- iv. Freeze pipes with time
- v. Once the earth temperature reaches 0 °C, water in the soil pores turns to ice. Then
- vi. Further cooling proceeds.
- vii. Rock and coarse-grained soils freeze faster than clays and silts

- viii. If the heat extraction is continued at a high rate, the thickness of the frozen wall will expand with time.
- ix. The frozen earth first forms in the shape of a vertical cylinder surrounding the
- x. Freeze pipes.
- xi. Once the wall has achieved its design thickness, the freeze plant is operated at a
- xii. reduced rate

- **Electro-osmosis.**

- Works on the principle that soil particles carry a negative charge, which attracts the positively charged ends of the water molecules, creating a balanced state
- If this balance is disturbed, the water will flow
- The disturbance of this natural balance is created by inserting into the ground two
- electrodes and passing an electric charge between them
- The positive electrode can be of steel rods or sheet piling, which will act as the anode, and a well point is installed to act as the cathode
- When an electric current is passed between the anode and the cathode it causes the positively charged water molecules to flow into the well point (cathode) where it is collected and pumped away to a discharge point.

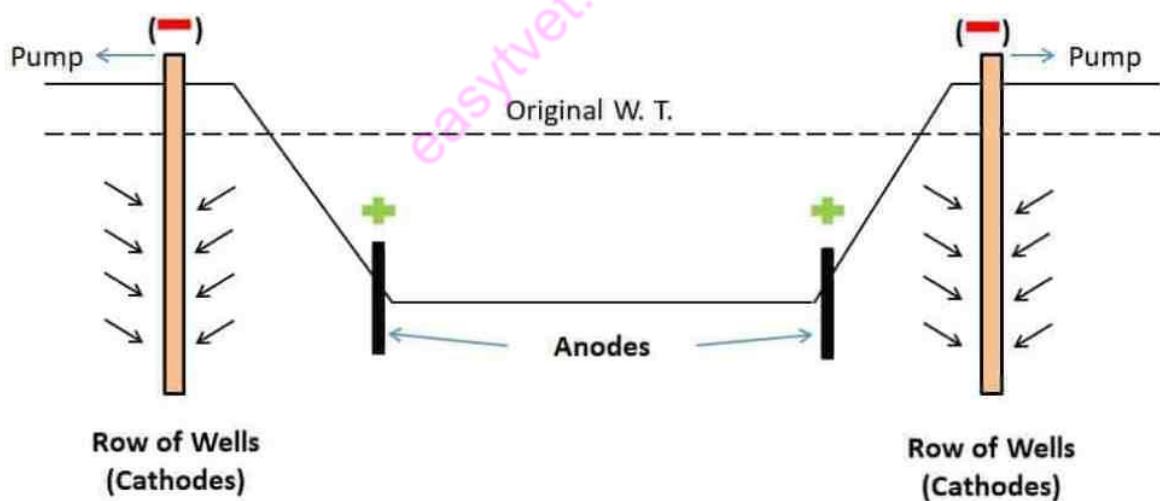

## Electro-Osmosis Method

Fig. 41 *Electro-osmosis.*

Ref. <https://civiconcepts.com/blog/dewatering>

### 2.2.4 Learning Activities

#### 2.2.4.1 Practical activities

The trainee is expected to excavate foundation as per the working drawings.

**Special instructions:** Use Building Code (BS 8110 & BS 449)

**2.2.4.2 Field/visit to a working construction site**

<b>Visit objective /Aim</b>	<b>In di ca to rs</b>	<b>Sp eci al ins tr uc tio n</b>
<p>To establish excavation, timbering and dewatering of foundation.</p>	<p>Procedure followed during excavation, timbering and dewatering of foundation</p>	<p>As per working drawing As soil analysis report As per dewatering methods</p>

	io n	
--	---------	--

**Table 1.4: Field visits, objectives, indicators and instruction for-establishment of excavation, timbering and dewatering of foundation.**

**2.2.5 Self-Assessment**

1. Why do we do earthwork support to foundation during excavation?
2. What factors determines the amount of support given to foundation trench during excavation?
3. What is the equipment used for dewatering in a foundation trench?
4. What methods that are used to control ground water during excavation work?

**2.2.6 Tools, Equipment, Supplies and materials**

Tools	Measuring tools Surveying tools Masonry tools
Equipment	Laptops Desktop PCs Masonry equipment
Supplies and materials	Personal protective equipment (PPEs) Working drawing Printer/plotting device Calculator Internet Timber/steel boards and nails
Resource	A functioning construction site. Building Code (BS 8110 & BS 449)

**Table 1.5: Tools, equipment, supplies and materials for- Excavation, timbering and dewatering of foundation.**

**2.2.7 References**

Rangwala, S.(Ed)(2009)*Building construction*.

Frank, C. (Ed)(1975)*Building Construction illustrated*.

Roy, C. (Ed) (1973) *Construction Technology*.



Edward, A. (Ed) (1985) *Fundamentals of Building Construction Materials and Method.*

Stephen, C. (Ed) (2006) *Barry's advanced construction of buildings*

### 2.2.8 Responses to Self –Assessment

1. Why do we do earthwork support to foundation during excavation?
  - **To prevent the walls from caving-in (collapse) causing severe injury or death to those required to work inside the trench.**
  - **To prevent additional cost to the builder to re-excavate and renew the damaged work in the trench.**
  
2. What factors determines the amount of support given to foundation trench during excavation?
  - **The type and nature of subsoil to be supported.**
  - **The depth of excavation.**
  - **The length of time the trench is to remain open.**
  - **The time of year or climatic conditions prevailing when the trench is excavated.**
  
3. What are the equipment used for dewatering in a foundation trench
  - **Jetting pump, for driving down the well points**
  - **Suction pump**
  - **Header pipe and**
  - **Rises pipe.**
  
4. What methods that are used to control ground water during excavation work?
  - **Plumbing Method**
  - **Dewatering**
  - **Electro osmosis**
  - **Grouting**
  - **Soil stabilization**

## 3.2 Learning Outcome 3: Lay building foundation

### 3.2.1 Introduction to the learning outcome

The trainee is expected to take foundation levels according to types of foundation and structural specifications, lay foundation blinding according building specifications, erect foundation formwork as per the specifications, position foundation reinforcement as per the structural details and carry out concreting according design requirements.

### 3.2.2 Performance Standard

- 1.1 Foundations levels are taken according to type of foundation and structural specifications
  - 1.2 Foundation blinding is laid according to building specifications
  - 1.3 Foundation formwork is erected as per specifications
  - 1.4 Foundation reinforcement is positioned as per the structural details
  - 1.5 Concreting is carried out according to design requirements

### 3.2.3 Information Sheet

#### 3.2.3.1 Checking the level of foundation by use of boring rod.

Procedures for using a boring rod to check the level of foundation.

- i. Step1: calculate the depth from top of profile to the desired level of the excavation using working drawings and measurement on site
- ii. Step2: make a measurement of staff called a boring rod which is the same length as the distance between the top of the profiles and the bottom of the trench
- iii. Step3: place the boring rod in the trench
- iv. Step4: Rig down until the top of the “T” on the boring rod lines up with the top the profiles

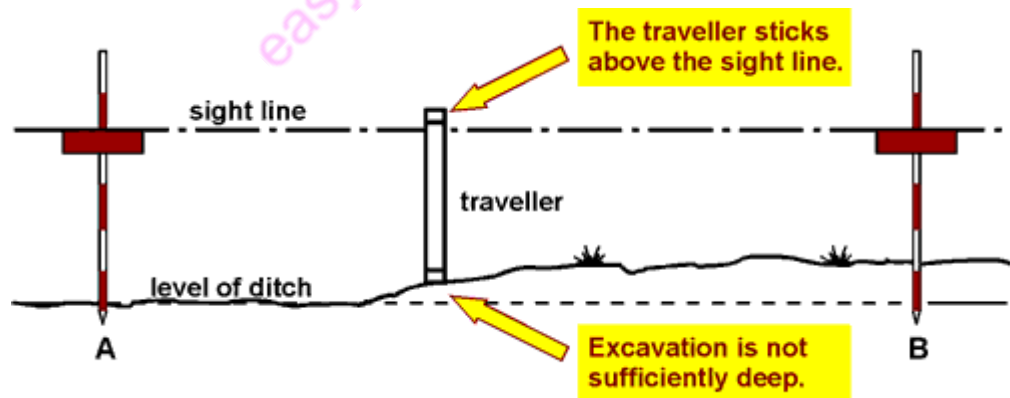

Figure 42 : a picture of an illustration of boring rod adopted from: *ruralwork .com*

#### 3.2.3.2 Procedure of laying concrete foundation

- I. **Bottoming** This is achieved by cutting high portions of the bed of the excavation and filling low places and compacting the loose earth. This operation is necessary in order to ensure that the concrete rest on a flat solid bed thus minimizing the possibility of differential settlement.

- II. Pegging** To maintain an even thickness throughout the foundation, pegs are driven into the bed of the trench leaving them projecting to a depth equal to the desired thickness of the concrete. During the laying of the concrete is tamped down to the level of the peg.

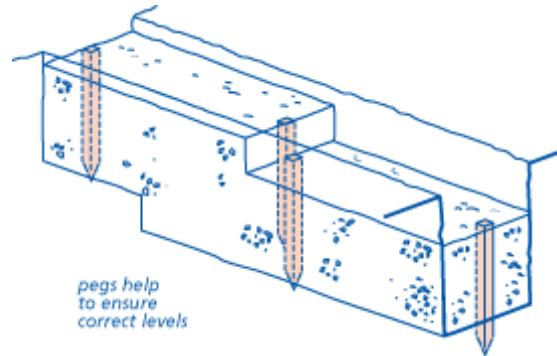

Figure 43: a picture of an illustration of pegging adopted from: [nhbccampaigns.com](http://nhbccampaigns.com)

- III. Wetting** During hot dry weather foundation trench must be thoroughly wetted before the mixed concrete is poured in, if this is not done the water in the concrete will be quickly absorbed by the dry soils of the trench with the result the concrete will develop false settings producing a weak foundation.
- IV. Pouring concrete.** Concrete must not be poured from a height that will allow segregation of the constituent aggregates. If the trench is deep and laying is being done manually, the concrete should be lowered in buckets and not poured directly from the wheelbarrow at the ground level. After pouring, the concrete is spread with a shovel and roughly tamped down to the required level. The foundation is then allowed to cure and gain strength for at least seven days. Before foundation wall is done.



Figure 44 : A picture of foundation formwork read to receive concrete  
adopted from: *shutterstock.com*

### 3.2.3.3 Preparation of pad foundation

1. Excavate to 1.2 m deep (dimensions as per the drawing specifications ) and compact soil in boundary. Set out to position of pad footing, and mark out pad footing to the reduced level ,then level the base of the pad.

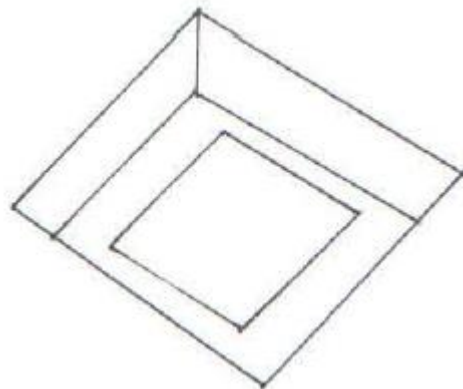

Fig. 45

2. Put up formwork and readjust setting out to ensure the pad footing is in the correct position.

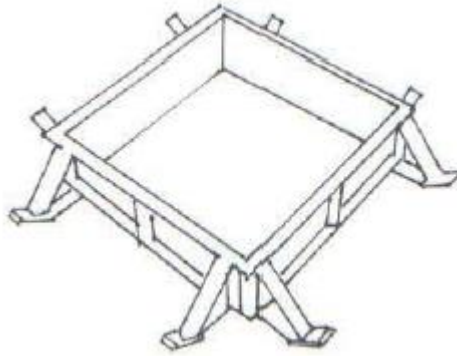

Fig. 46

3. Fill in with a weak concrete blinding(lean) of 1:4:8 . and put up spacer blocks. Leave the blinding to set and hardened.

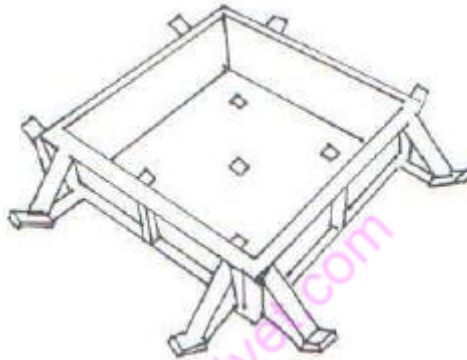

Fig. 47

4. Lay the reinforcements for the pads which consist of the main rebar and transverse rebar in positions as per the drawing specifications.

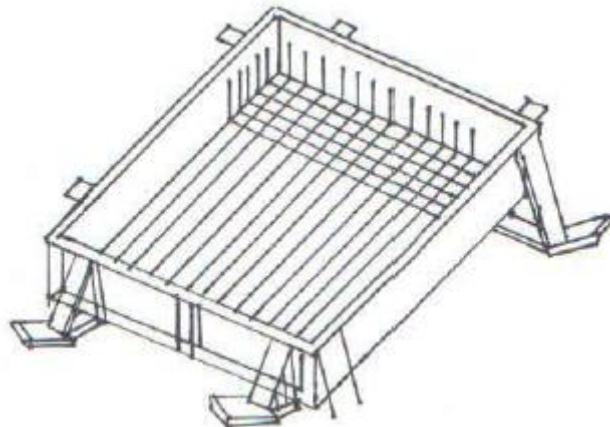

Fig.48

5. Erect the starter bars for the columns after placing the pad reinforcement grid .and position starter bars by bending and tying to pad reinforcement.. Place the bars such that the resulting column is centrally placed on the pad base

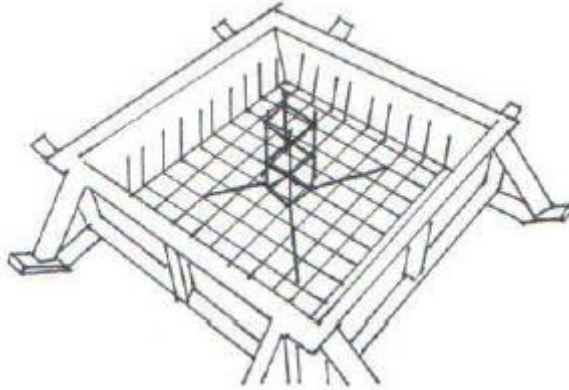

Fig. 49

6. Cast grade 30 concrete inside the formwork.

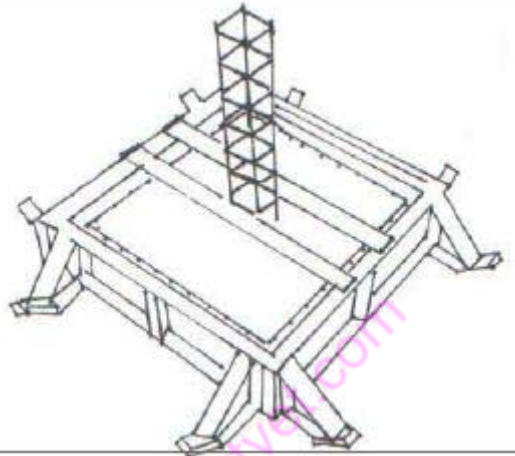

Fig. 50

7. After the concrete has set, the formwork is removed and formwork of column stump is installed.

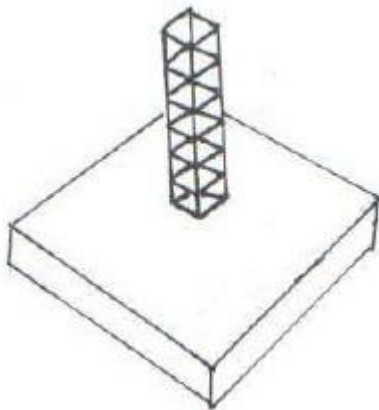

Fig. 51

8. Place a formwork of 75mm high on the pad and fill it with grade 30 concrete to form the column kicker. Dismantle the formwork after 3 days, and then backfill the earth.



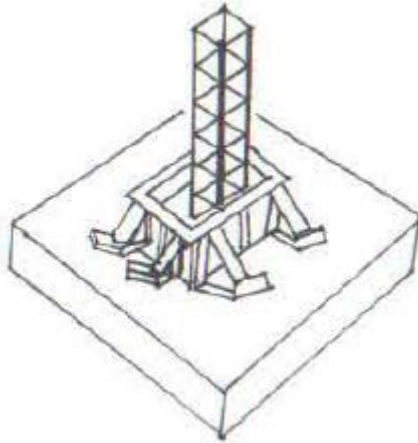

Figure 52 : A picture showing position of column kicker in pad foudation

*Ref. Building Construction 1 BLD 60303( Tylor's University)page 49  
(slide share*

#### **3.2.3.4 Preparation for raft foundation.**

- (i) The ground to receive the raft is prepared by excavating the whole area under the raft to a minimum depth of 300mm.



Figure 53

<https://www.slideshare.net/sumit57/report-1507200831511va1app6892>

- (ii) The bottom of the excavation is the leveled and hard core laid and compacted in layers of 150mm

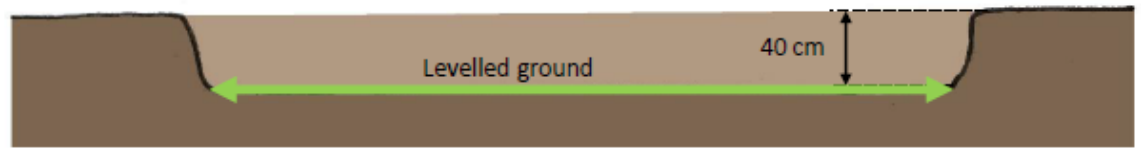

Figure 54

<https://www.slideshare.net/sumit57/report-1507200831511va1app6892>

- (iii) A compacted hardcore layer (Used as solid working base) and a blinding layer (Used to prevent wet concrete from running down the hardcore) is added inside. The edge of the hardcore is stepped to allow for the thickened edge of raft. Finally this is blinded by using ashes, quarry dust or weak concrete mixed in ratio of 1:4:8. A 75mm blinding layer is laid on hard core to provide a level bed for the raft foundation.

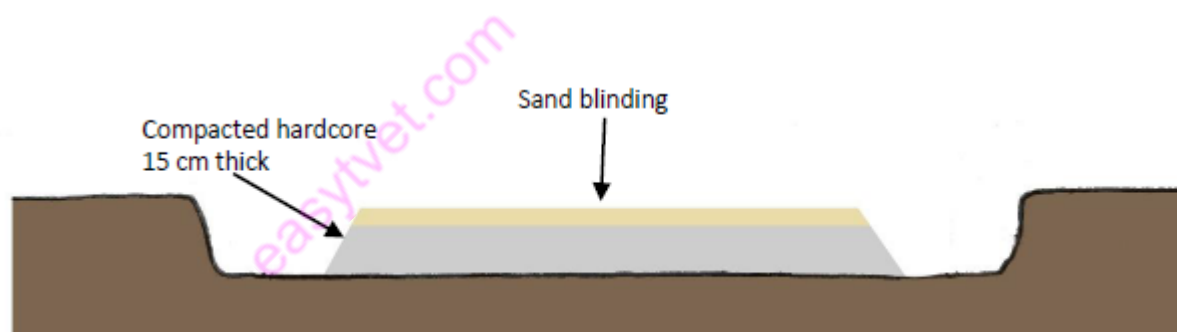

Figure 55

<https://www.slideshare.net/sumit57/report-1507200831511va1app6892>

- (iv) The reinforcement mesh or Reinforcements are added are laid with spacer blocks to ensure a concrete cover to give more strength to the foundation. Top reinforcement bars are kept in position by Z shaped metal stools of shot length head to the bottom reinforcement and link to top reinforcement.



Figure 56

<https://www.slideshare.net/sumit57/report-1507200831511va1app6892>

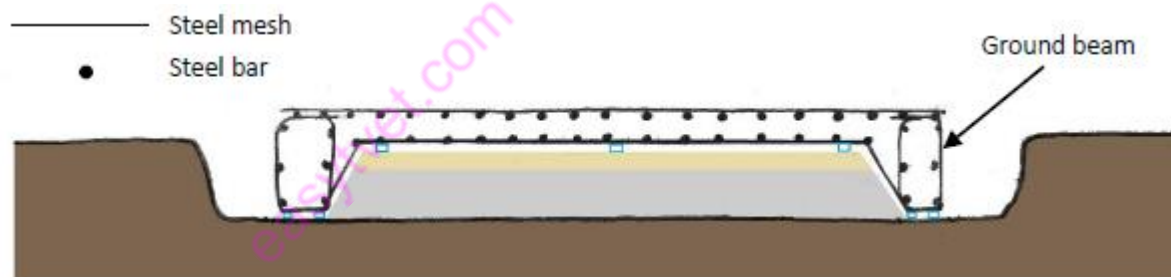

Figure 57

<https://www.slideshare.net/sumit57/report-1507200831511va1app6892>

(v) Wood is used as the formwork to hold the concrete in shape

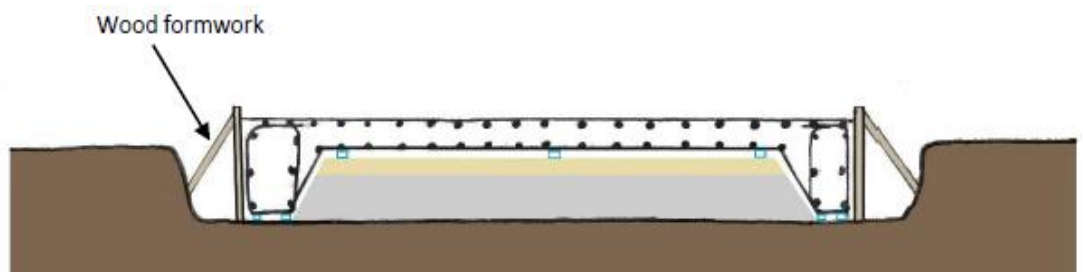

Figure 58

<https://www.slideshare.net/sumit57/report-1507200831511va1app6892>

(vi) Concrete for the slab and the thickened edges is poured to floor level, compacted and leveled to receive the walls, then left to dry.



Figure 59

<https://www.slideshare.net/sumit57/report-1507200831511va1app6892>

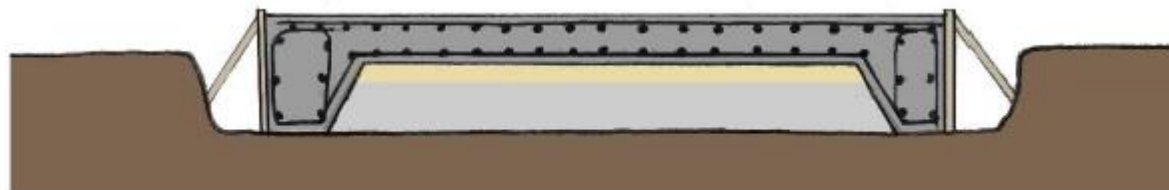

Figure 60

<https://www.slideshare.net/sumit57/report-1507200831511va1app6892>

(vii) Care should be taken to ensure that a uniform compacted concrete over the entire floor area is achieved. Curing of the finished concrete should be done for at least 14 days.



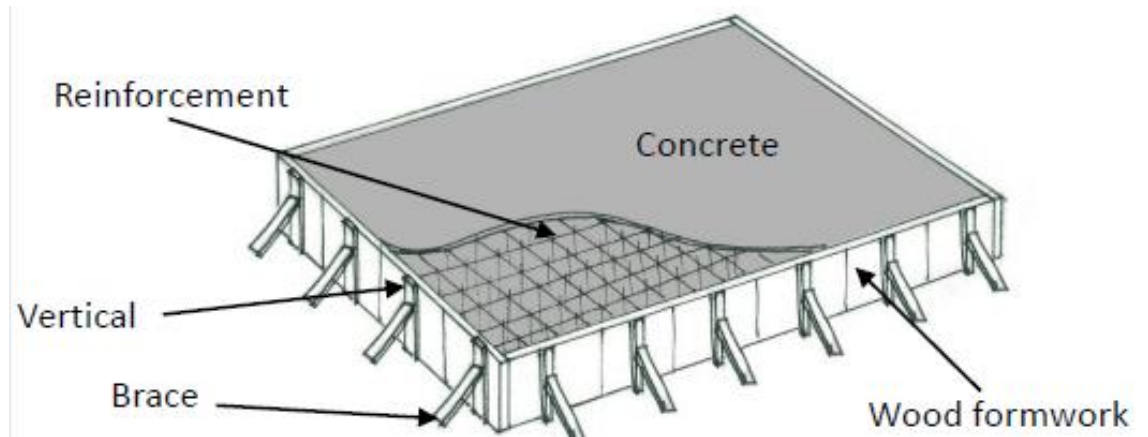
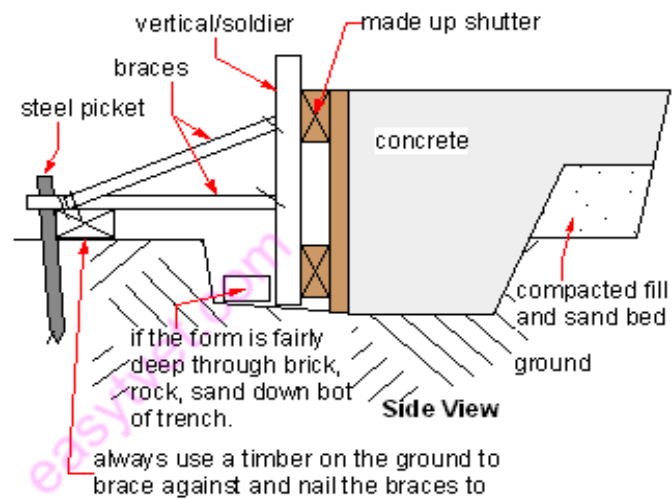

Fig. 61



**Raft slabs - Sketch of the formwork layout**

Figure 62

<http://www.builderbill-diy-help.com/raft-slab.html>

(viii) Then the soil is added to fill the gap between the foundation and the soil

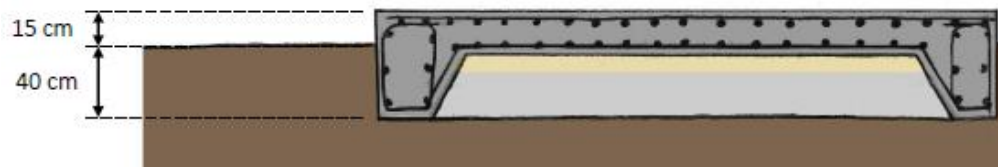

Figure 63

Ref. <https://www.slideshare.net/sumit57/report-1507200831511va1app6892>

### 3.2.4 Learning Activities

#### 3.2.4.1 Practical Activities

The trainee is expected to take foundation levels according to types of foundation and structural specifications.

**Special instructions:** Use Building Code (BS 8110 & BS 449)

#### 3.2.4.2 Field/Visit to a working construction site

Visit objective/Aim	Indicators	Special instruction
To establish laying of foundation blinding, erection of formwork, positioning of foundation reinforcement and concreting of foundation.	Procedure followed during laying of foundation, erection of formwork, positioning of foundation reinforcement and concreting of foundation	As per the structural details As per specification

**Table 1.6: Field visits objectives, indicators and special instructions for- laying of foundation blinding, erection of formwork, positioning of foundation reinforcement and concreting of foundation.**

#### 3.2.5 Self-Assessment

- Why do we do bottoming of foundation base?
- What is the importance of pegging during setting out of foundation base?
- Why do we do wetting to foundation bottom before pouring of concrete?
- Why do we prevent segregation of concrete during pouring into foundation trench?



### 3.2.6 Tools, Equipment, Supplies and Materials

Tools	Measuring tools Surveying tools Masonry tools
Equipment	Laptops Desktop PCs Masonry equipment Concreting plant
Supplies and materials	Personal protective equipment (PPEs) Working drawing Printer/plotting device Calculator Internet Timber/steel boards and nails
Resource	A functioning construction site. Building Code (BS 8110 & BS 449)

**Table 1.7: Tools, equipment, supplies and materials for- laying of foundation blinding, erection of formwork, positioning of foundation reinforcement and concreting of foundation.**

### 3.2.7 References

Rangwala, S.(Ed)(2009)*Building construction*.

Frank, C. (Ed)(1975)*Building Construction illustrated*.

Roy, C. (Ed) (1973) *Construction Technology*.

Edward, A. (Ed) (1985) *Fundamentals of Building Construction Materials and Method*.

Stephen, C. (Ed) (2006) *Barry's advanced construction of buildings*

Taylor's University, Building Construction 1 BLD 60303 (slide share)

<https://www.slideshare.net/sumit57/report-1507200831511va1app6892>

<http://www.builderbill-diy-help.com/raft-slab.html>

### 3.2.8 Responses to Self-Assessment

- i. Why do we do bottoming of foundation base?
  - **In order to ensure that the concrete rest on a flat solid bed thus minimizing the possibility of differential settlement.**
- ii. What is the importance of pegging during setting out of foundation base?
  - **To maintain an even thickness throughout the foundation base.**
- iii. Why do we do wetting to foundation bottom before pouring of concrete?
  - **To prevent fresh concrete from developing false settings that will lead to a weak foundation.**
- iv. Why do we prevent segregation of concrete during pouring into foundation trench?
  - **Segregation of concrete if allowed will lead to weak foundation slab.**

## 4.2 Learning Outcome 4: Erect foundation walls

### 4.2.1 Introduction to the learning outcome

The trainee is expected to set out foundation walling as per the working drawings and construct foundation walling as per structural specifications.

### 4.2.2 Performance Standard

- 4.1 Foundation wall is set out as per working drawing
- 4.2 Foundation walling is constructed as per structural specifications

### 4.2.3 Information Sheet

#### 4.2.3.1 Foundation wall:

Walls are vertical and continuous solid structures, usually constructed from materials such as clay, stone, concrete, timber or metal. Walls can be classified with respect to their functional requirements as internal and external walls. They can also be defined as load bearing (carrying imposed loads from roofs and floors in addition to their own weight) and non-load bearing (e.g. partition), non-load bearing is with respect to the structural requirements. There are variably two types of walls, solid wall and framed wall.

#### 4.2.3.2 A solid wall (Masonry wall).

Is constructed either of blocks of brick, burned clay, stone or concrete. These are laid in mortar to overlap to form a bond (bonding) or as a monolithic (e.g. concrete wall). A frame wall is constructed from a frame of small sections of timber, concrete or metal joined together to provide strength and rigidity, and between the members of the

frame thin panels of some material are then fixed to the frames to fulfill the functional requirements of the particular wall.

#### 4.2.3.3 Bricks-

are small blocks manufactured from burnt clay that can be handled with one hand, and its length is twice the width plus one mortar joint. Blocks made from sand and lime and blocks made of concrete manufactured in clay brick size are also called bricks. The standard size is 215mm x 102.5mm x 65mm which with 10mm mortar joint becomes 225mm x 112.5mm x 75mm.

There are various types of bricks of the same standard format are classified with respect to the material used, composition, extent of mixing and curing, duration and amount of forming applied. Some of these of bricks are: commons, facings, engineering bricks, semi-engineering bricks, and composition of clay, flattons, stocks, marts, Gautts, clay shale bricks, calcium silicate bricks, flint-lime bricks, and hollow, perforated and special bricks.

#### 4.2.3.4 Brick Bonding

To build or construct a wall of brick or blocks, it is usual to lay the bricks in some regular pattern. The brick courses or rows in a wall are arranged to ensure that each brick overlaps or bear upon two or more bricks immediately below it. The process of laying the bricks across each other and binding them together is called bonding. The amount of overlap and the part of the brick used determined the pattern or bond of brickwork. Bonding of bricks can also be defined as the arrangement of bricks in which no vertical joint of one course is exactly over the one in the next course above or below it, and having the greatest possible amount of lap which is usually atleast  $\frac{1}{4}$  of the length of a brick.

The main purpose of bonding is provide maximum strength, lateral stability and resistance to side thrust, and it distributes vertical and horizontal loads over a large area of the wall. A secondary purpose of bonding is to provide appearance (decoration)

#### 4.2.3.5 Brick terms in bonding

- **Course:** - This is the name given to the row of bricks between two bed joints, and the thickness is taken as one brick plus one mortar joint.
- **Quoin:** - Is the external corner of a wall.
- **Perpends:** - The vertical joints of the face of the wall. For good bond it is necessary that these joint should be vertically above one another in alternate courses.
- **Stretcher face:** - This is front length and height elevation of a brick, i.e. 215 x 65mm face.
- **Header face:** - the side width and height face of a brick, i.e. 102.5 x 65mm face.
- **Lap:** - The horizontal distance between the vertical joint in two successive courses.
- **King closer:** - these are bricks cut so that one end is half the width of the brick. They are used in the construction of reveal to obtain rebated jamb in openings.

- **Bats:** - Pieces of bricks usually known according to their fraction of a whole brick, e.g.  $\frac{1}{2}$  or  $\frac{3}{4}$  bats.
- **Queen closers:** - These are bricks made with the same length and thickness as ordinary brick, but half the width placed usually next to the quoin leader to obtain the required lap.
- **Pointing and Jointing:** - Pointing is the application of a special mortar to the horizontal and vertical mortar joint of a brick wall externally in order to ensure that the brick joints are solidly filled with mortar to make them water tight and secondly to give some amount of decoration to the external face of the wall. Jointing is the method of filling brick joints in a brick wall during the laying operations.

#### 4.2.3.6 Types of brick bonds

The choice of any brick bond is influence by the following factors:

- Prevailing environmental or site conditions
- Thickness of the wall
- The purpose for the wall construction, i.e. either strength or decoration.

#### 2. **Stretcher Bond:** -

This type of bond is where bricks are laid with every brick showing a stretcher face or long face on each side of the wall, hence the thickness of the wall is to be 102.5mm.

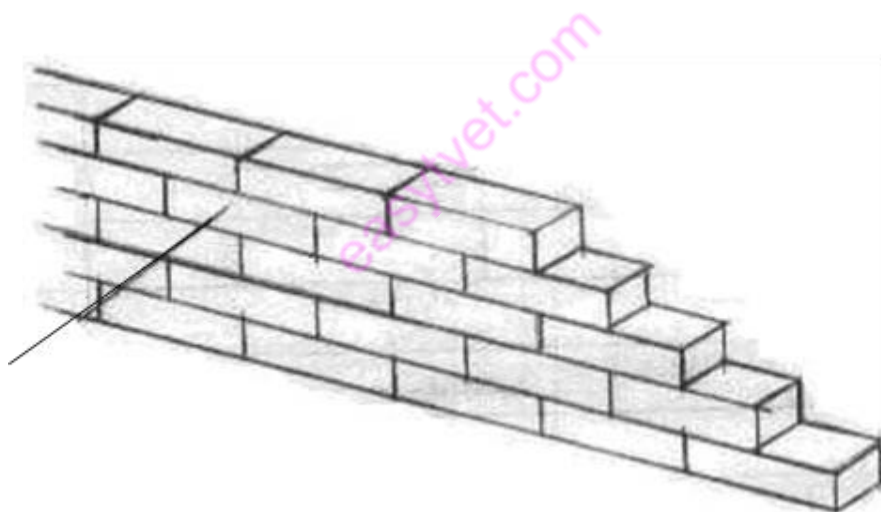

Figure 64 : an illustration of stretcher bond

#### 3. **Header (Heading) Bond:** -

This arrangement shows the header face of every brick, smith 215mm thickness. It is rarely in use, because it has no attractive finish (too many joints).

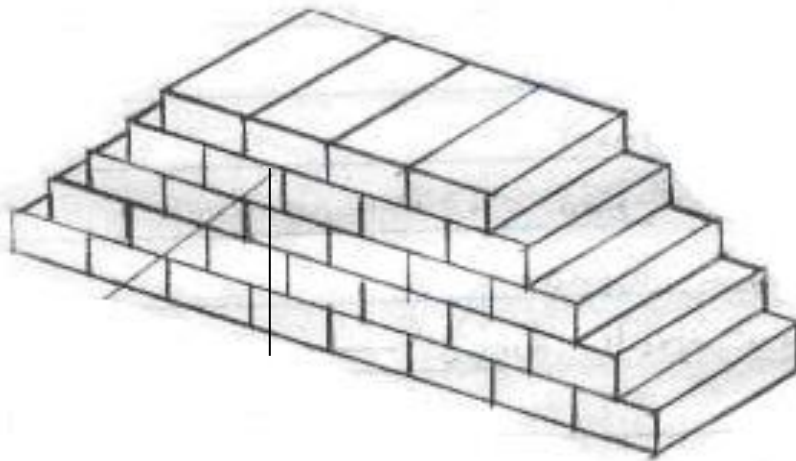

Figure 65: an illustration of Flemish bond

4. **English Bond:** -

This arrangement shows the bricks in one course or layer with their header faces and in the course below and above show their stretcher faces.

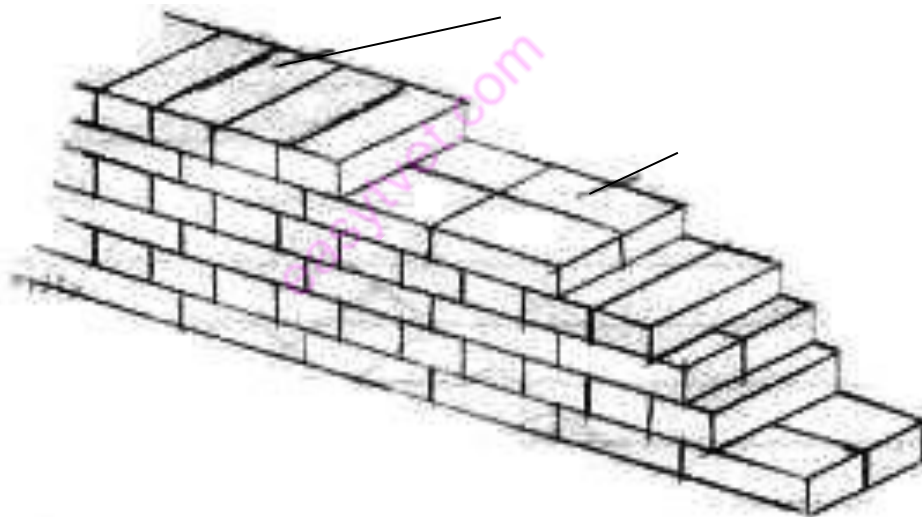

Figure 66: an illustration of English bond

5. **Flemish Bond:** -

The arrangement here involves bricks in every course or layer showing alternating header and stretcher faces. This bond is more attractive than the English bond, because the header face of many bricks is dark, and they are separated in this bond as against the English where they are continuous.

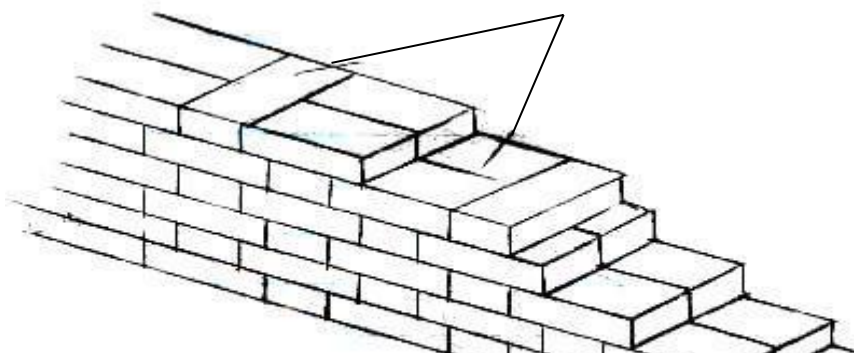

Figure 67: an illustration of Flemish bond

#### 4.2.3.7 Blocks

for building are wall units larger in size than a brick. They are made of concrete or clay.

**a. Concrete Blocks: -**

Are manufactured from Portland cement and aggregates, as solid and hollow or cellular blocks. They are used both internally and externally for non-load-bearing and load bearing walls respectively. Concrete blocks suffer moisture movement which cause cracking of plaster finish, vertical joints are provided in long block walls of intervals of up to twice the height of the wall to resist the cracking. There are three types of concrete blocks:

**b. Dense aggregate concrete blocks: -**

Are made from a mix of 1 part of Portland cement to 6 or 8 part of aggregate by volume. They are very heavy but have less unshing strength than most bricks. They are used for general building including below the ground, and for internal and external load-bearing walls.

**c. Lightweight aggregate concrete blocks: -**

Are made of Portland cement and any of the following lightweight aggregates. Granulated or foamed blast furnace slag, expanded clay or shale, or wall-burned furnace clinker. The blocks are used in building including below ground, in internal walls and inner leaf of cavity-walls. The furnace clinker blocks which are the cheapest are used extensively for walls of houses. The foamed blast-furnace slag blocks (good thermal insulators) are used for walls of large framed buildings because of their lightness in weight

#### 4.2.3.8 Bonding

Concrete blocks are normally laid in stretcher bond, the various thickness of blocks are made to suit most wall thickness requirement. Bonding is done with mortar with roughly the density, strength and drying shrinkage as the

Blocks, normally 1:1:6 Cement/lime/sand by volume, or 1:2:9 Cement/lime/sand by volume.

#### 4.2.3.9 Clay blocks: -

Are made from selected bricks clay which are press moulded and burnt. They are lightweight blocks, hard, dense and hollow to reduce shrinkage during firing. They are made or manufactured with grooves to provide a key for plaster. They



suffer less moisture movement, are resistant to fire, and are mainly used for non-load bearing partitions. Sizes are 290 long x 215 heights x 62.5, 75, 100 and 150 thick.

#### **4.2.3.10 Stone Masonry:**

Choice of stone for wall construction is generally limited to its availability in the construction area. Great amount of natural stone deposits in some parts of the country is obvious from its abundant use as external cladding in these areas.

Classes of building stone include: -

- **Igneous rock**, formed from volcanic deposits, e.g. granite, basalt.
- **Sedimentary rock** disintegrated and reformed by centuries of rock wreathes e.g. sandstone, limestone.
- **Metamorphic rock** disintegrated and reformed by pressurization or heat, e.g. marble, slate.

Reconstituted or artificial stone of natural stone aggregates and cement moulded into convenient size blocks of concrete are also available. It is a substitute for natural stone and has the advantage of freedom from defects.

#### **4.2.3.11 Bonding –**

Stonework maybe coursed by dressing the stone to an agreeable size of about 200mm or 300mm square. Alternatively, walls may be constructed from stones as they arrive from the quarry. Awkward covers are removed and the result is an uncoursed wall known as random rubble. Snacked rubbed walling is a compromise, and is composed of squared stone of irregular size with long vertical joints interrupted by small square stones called ‘snacks’ of 50mm minimum dimension. Stone cladding are also use as non-load bearing columns.

#### **4.2.3.12 Back filling of foundation trench.**

It may be defined as the process of reusing or replacing the soil that is removed during construction of the structure to strengthen the foundation or other structural members.

#### **Purpose of backfilling**

- i. To increase the strength of the foundation to resist all the load coming from superstructure.
- ii. To provide support to the foundation to the structure.
- iii. To increase the overall stability performance of the building.

#### **Factors affecting backfill in foundation**

- Selection of suitable backfill material
- Compaction of the backfill material
- Selection of the period of the backfilling

#### 4.2.3.13 Types of backfill material

- **Coarse-Grained soil**-are one of the commonly used backfill materials include mixed gravel soil and sand soil
- **Fine grained-soil**- with low medium plasticity can be used as backfill they include silty or clayey, fine sand, lean clays and graveled clay
- **Commercial by product**-also available in the market can be used as a backfill materials, includes ash and furnace slag
- **Controlled low strength**-materials is a cementitious material primarily used for process of backfilling

#### 4.2.3.14 Procedure of backfilling a foundation

- i. Initially the foundation has to be used for a period of at least five to several days before commencing the backfill to prevent the cracking.
- ii. The ground over which the backfill process to be carried out must be thoroughly cleaned; if water is present it must be pumped out or bailed out.
- iii. Depending upon the engineering properties and site condition the suitable backfill material must be selected; a mixture of the backfill material can also be used.
- iv. If possible the refilling materials can be used from the excavated earth can also be useful in the reduction of the overall. But it must be taken care that excavated material is well clean free from rubbish.
- v. The backfill is then from corners the fill material must be spread evenly.
- vi. An excavator can be used to fill material up to 12 inches on the side of the area. The fill dually compacted employing a compaction roll or suitable compaction equipment.
- vii. The filling must be done in subsequent layers with a thickness of 150mm-200mm each. Then each layer is watered and further compacted using wooden logs rammers or steel rammers.



Figure 68: A picture showing backfill of foundation wall adopted from: *constructionmenter.com*

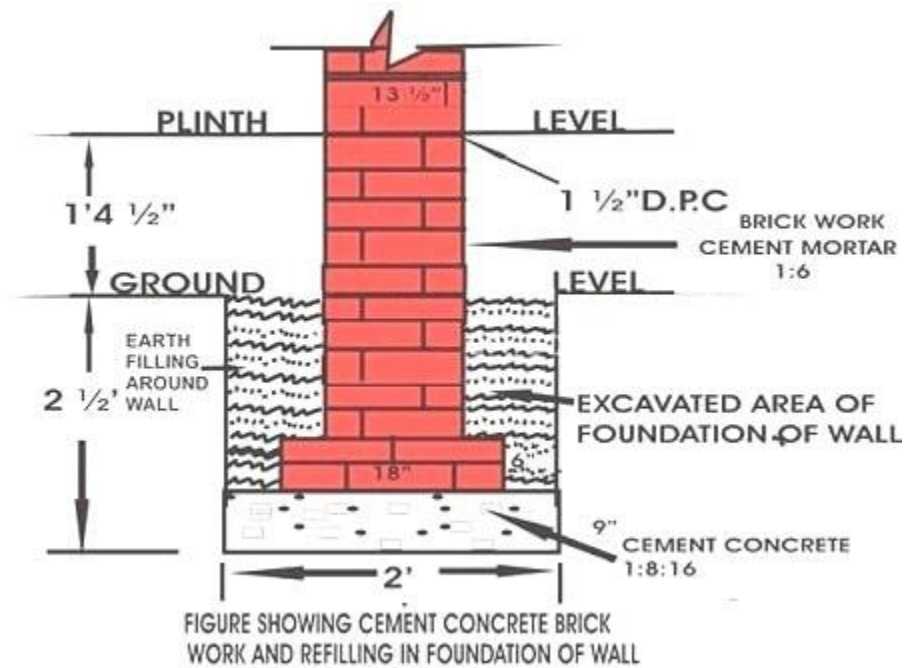

Figure 69: a picture of an illustration of foundation wall details adopted from: *slideshare.com*

### 4.2.3 Learning Activities

#### 4.2.3.1 Practical Activities

**TASK:** The trainee is expected to set out foundation walling as per the working drawings.

**Special instructions:** Use Building Code (BS 8110 & BS 449).

#### 4.2.3.2 Field/visit to a working construction site

Visit objective/Aim	Indicators	Special instruction
To establish Setting out and construction of foundation walling.	Procedure followed during setting out and construction of foundation walling.	As per working drawing. As per structural specification

**Table 1.8: Field visit objectives, indicators and special instruction for Setting out and construction of foundation walling.**

#### 4.2.4 Self-Assessment

1. What factors that will guide you when choosing the types of brick bond to use during construction of foundation wall?
2. What are the reasons of backfilling a foundation wall?
3. What are the procedures of backfilling a foundation?
4. What are the classes of building stones used for wall construction?

#### 4.2.5 Tools, Equipment, Supplies and Materials.

Tools	Measuring tools Surveying tools Masonry tools
Equipment	Laptops Desktop PCs

	Masonry equipment
Supplies and materials	Personal protective equipment (PPEs) Working drawing Printer/plotting device Calculator Internet Timber/steel boards and nails
Resource	A functioning construction site. Building Code (BS 8110 & BS 449)

**Table 1.9:** Tools, equipment, supplies and materials for-Setting out and construction of foundation walling.

#### 4.2.6 References

*Rangwala, S.(Ed)(2009)Building construction.*

*Frank, C. (Ed)(1975)Building Construction illustrated.*

*Roy, C. (Ed) (1973) Construction Technology.*

*Edward, A. (Ed) (1985) Fundamentals of Building Construction Materials and Method.*

*Stephen, C. (Ed) (2006) Barry's advanced construction of buildings*

#### 4.2.7 Responses to Self-Assessment

1. What factors that will guide you when choosing the types of brick bond to use during construction of foundation wall?
  - **Prevailing environmental or site conditions**
  - **Thickness of the wall**
  - **The purpose for the wall construction, i.e. either strength or decoration.**
  
2. What are the reasons for backfilling a foundation wall?
  - **To increase the strength of the foundation to resist all the load coming from superstructure.**
  - **To provide support to the foundation to the structure.**
  - **To increase the overall stability performance of the building.**
  
3. What are the procedures of backfilling a foundation?

- i. **Initially the foundation has to be used for a period of at least five to several days before commencing the backfill to prevent the cracking.**
  - ii. **The ground over which the backfill process to be carried out must be thoroughly cleaned; if water is present it must be pumped out or bailed out.**
  - iii. **Depending upon the engineering properties and site condition the suitable backfill material must be selected; a mixture of the backfill material can also be used.**
  - iv. **If possible the refilling materials can be used from the excavated earth can also be useful in the reduction of the overall. But it must be taken care that excavated material is well clean free from rubbish.**
  - v. **The backfill is then from corners the fill material must be spread evenly.**
  - vi. **An excavator can be used to fill material up to 12 inches on the side of the area. The fill dually compacted employing a compaction roll or suitable compaction equipment.**
  - vii. **The filling must be done in subsequent layers with a thickness of 150mm-200mm each. Then each layer is watered and further compacted using wooden logs rammers or steel rammers.**
4. What are the classes of building stones used for wall construction?
- **Igneous rock, formed from volcanic deposits, e.g. granite, basalt.**
  - **Sedimentary rock disintegrated and reformed by centuries of rock wreathes e.g. sandstone, limestone.**
  - **Metamorphic rock disintegrated and reformed by pressurization or heat, e.g. marble, slate.**

## **5.2 Learning Outcome 5: Construct solid ground floor**

### **5.2.1 Introduction to the learning outcome**

The trainee is expected to level and compact floor base according to building code requirements, lay and compact hard-core layer as per specification and building code, lay and compact blinding layer as per the building code, spray anti- termite as per the building code and manufactures specifications, lay DPM as per building code, lay BRC as per building code, position spacer blocks as per specification, erect formwork to edges of slab and place concrete according to building code.

### **5.2.2 Performance Standard**

- 5.1 Floor base is levelled and compacted according to building code requirement
- 5.2 Hard-core layer is laid and compacted as per specifications and building code
- 5.3 Blinding layer is laid and compacted as per building code
- 5.4 Anti- termite is sprayed as per building code and manufacturer's specifications
- 5.5 DPM is laid as per building code



- 5.6 BRC is laid as per building code
- 5.7 Spacer blocks are positioned as per specifications
- 5.8 Formwork to edges of slab is erected
- 5.9 Concrete is placed according to building code

### 5.2.3 Information Sheet

#### 5.2.3.1 Solid Ground Floors- construction

The floor is constructed on a bed of well-compacted hard material called hardcore. It provides the following benefits:

- A level, horizontal surface on which to place the floor slab;
- A firm, dry working surface on which to place the concrete for the floor slab;
- It reduces the rise of ground moisture by virtue of the large voids between the pieces of hardcore which eliminate capillary paths;
- It provides additional support to the floor above should the ground beneath suffer settlement or subsidence.
- Hardcore consists of broken bricks, stones, concrete or rubble.
- It must not contain materials that are soft or can crumble easily and must not contain deleterious material that will either rot or corrode; leaving voids or reacts with the concrete.
- The lumps of hardcore should be relatively large, but generally not larger than 75 mm in diameter.
- It should be laid to a minimum thickness of 100 mm, be well compacted and have its surface 'blinded' with a layer of ash or sand.
- This helps to fill in the large voids between the pieces of hardcore on the surface and prevents loss of concrete into these voids and also covers the sharp points on the surface pieces of hardcore that could puncture a damp proof membrane DPM placed above.
- The DPM prevents the rise of ground moisture through the floor construction. In order for it to be functional it must be continuous, impervious and join up with the DPM in the walls.
- There are three positions in which the DPM may be located within the floor construction:
  1. Sandwiched between the blinding above the hardcore and the concrete slab;
  2. Sandwiched between the top of the concrete slab and the screed;
  3. Sandwiched between the surface of the slab and the floor finish.
- If the DPC is to be placed between the blinding and the concrete slab it will normally comprise of a 1200 gauge low-density polyethylene sheet
- This sheet, being of finite width must be lapped or sealed effectively at its edge joints.

- Alternatively bitumen sheet may be used as a DPC in this position.

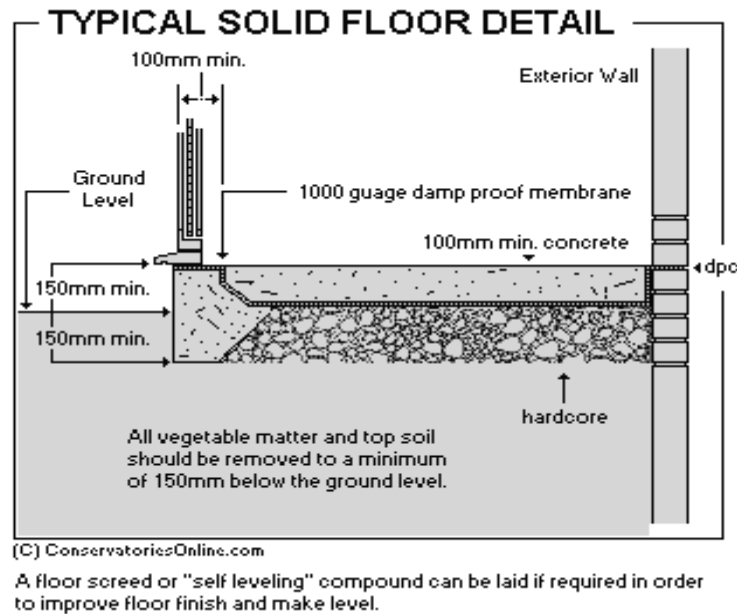

Figure 70: a picture of details of solid ground floor adopted from: *pinterest.com*

### 5.2.3.2 Damp Proofing in Solid ground floor.

#### Rising and Seepage of Ground and Underground Water-

If water is to rise or seep in a wall or floor, a constant supply must be available at the base and side of the floor and wall. Water rises by an upward capillary pull between the masonry pores. On building sites with high water table and on sloping sites where water may run down to the building, site concrete, floors and walls are likely to get damp by the respective rising and seepage or moisture/water. The obvious indication of rising damp and seepage is the dark staining above the skirting, bored on the interior of a wall.

### 5.2.3.3 Importance of Damp Proofing in Substructure Works

- Damp proofing is the principle of preventing moisture entering buildings and causing dampness which might be as a result of water/moisture rising up the wall and floor from the ground forced through the structure, or seeping through the forces of walls.
- Damp proofing helps the prevention of moisture rising up the floor or seeping through walls, causing efflorescence and damage to the walls and floor finishes.
- Generally, damp proofing helps to maintain the quality, strength, stability, durability and resistance to moisture/water of structures. It also helps to maintain an appreciable room temperature. And to provide protection to

final finishing materials to concrete floors. A damp proofing material must be incorporated in concrete floors.

#### **5.2.3.4 Processes of Damp Proofing**

The process of damp proofing involves the provision of a continuous layer of horizontal damp proof coarse (DPC) at about 150mm above finished ground level in walls whose foundation are below the ground. And the provision of a damp proof membrane (DPC) for the entire area on top is between or under the over site concrete slab.

The DPC should be impenetrable and continuous for the whole length and thickness of the wall and be at least 150mm above finished ground level. This is to prevent or avoid the possibility of a build-up of materials against the wall acting as a bridge for moisture seeping through the wall

#### **5.2.3.5 Types of Damp Proofing Materials**-they grouped into two categories:

##### **i. Damp proof membrane materials**

- Hot, pitch or bitumen
- Bitumen sheets/solutions/tar
- Mastic asphalt
- Polythene sheet

##### **ii. Damp Proof course**

###### **1. Flexible DPC material**

- Lead
- Copper
- Bitumen
- Polythene sheet

###### **2. Semi-Rigid DPC materials**

- Slates
- Bricks

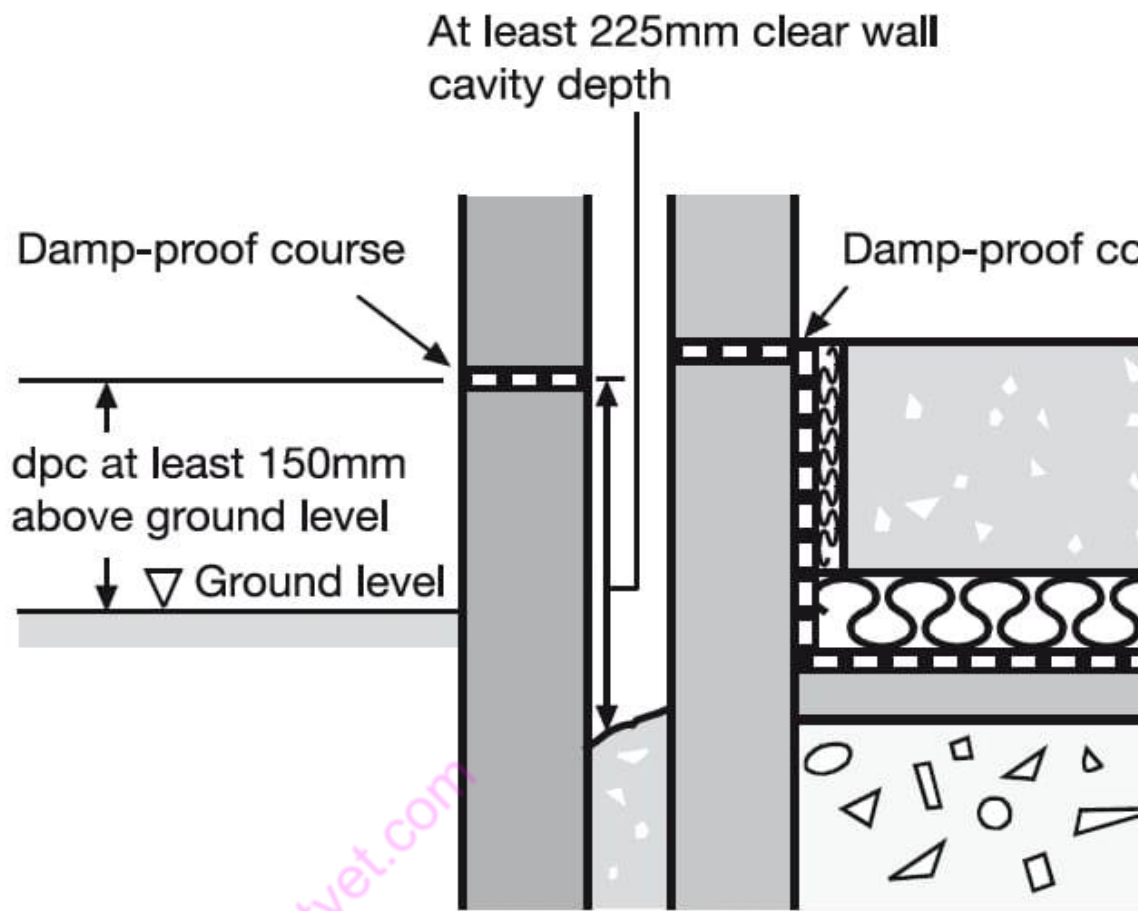

Figure 71: a picture of damp proofing details adopted from: *contractor.org*



Figure 72: A picture of damp proofing in ground floor adopted from: *pinters.com*

### 5.2.3.6 Hard Core –

This is an application of suitable material such as broken bricks, stones and tiles, clinker, gravel, quarry waste, which are required on the building site to fill hollow over site concrete work. On wet sites, it may be used to provide a firm working surface and to prevent contamination of the lower part of the wet concrete during compaction. The particle materials should be hard and durable, not subject to decay or breakdown by weather or chemical attack, and it should be easily placed and well compacted. The hardcore should be spread until it is roughly level and round until it forms a compact bed for the over-site concrete. The hardcore bed is usually 100 to 300mm thick. It is spread to such thickness as required to raise the finished surface of the over-site concrete. Generally, the hardcore bed serves as a solid working base for building and as a bed to receive over-site.

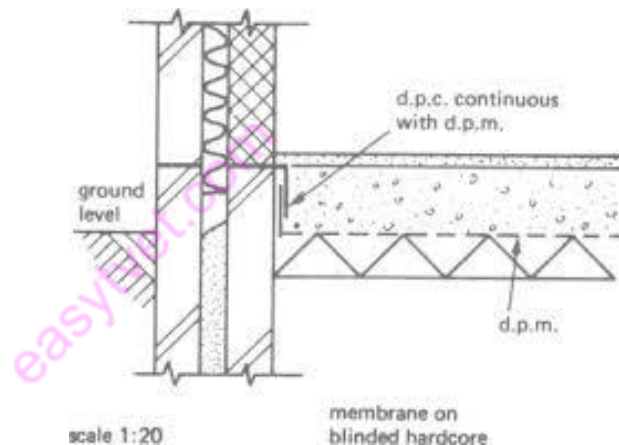

Figure 73: A picture of an illustration of hard core details Adopted from: *link.springer.com*

### 5.2.3.7 Blinding-

Is a process of providing a layer of dry concrete, coarse clinker or ash over the hardcore before placing the over site concrete. Before the concrete is laid it is usual to blind the top surface of the hardcore. The purpose is to prevent the wet concrete running down between the lumps of broken brick or stone, as it would make easier for water to seep through the hardcore and could be wasteful of concrete. To blind or seal, the top surface of the hardcore a thin layer of very dry coarse concrete can be spread over it, or a thin layer of coarse clinker or ash can be used. The blinding layer, or coat, will be about 50mm thick, and on it the site concrete is spread and finished with a true level top surface.

### 5.2.3.8 Use of Anti-Termite Treatment in Foundation Works-

A problem in tropical climates is the possibility that timber maybe attacked by termites. The common termite or white ant forms colonies in the ground where a nest housing the queen is found. The termites can enter a building through the ground looking for timber to consume. The junction of the wall and floor is a particularly vulnerable point. There are some precautions which can be taken to reduce the risk of termite attack:

- i. The area around the building should be inspected for termite nests, which should be dug out and treated with insecticide.
- ii. During excavation work for the foundation and hardcore bed, the exposed soil should be treated with insecticide, in an anticipation of termite attack.
- iii. The ground floor concrete should be raised above the adjoining ground level and should project beyond the outer wall face.

### 5.2.3.9 Methods of Termite Treatments

#### ❖ Pre-construction treatment:

Site preparation: All the waste wood, grass, stumps, roots etc. lying buried or on the surface are to be removed.

#### a. Treatment of excavated foundation trenches

The bottom and sides of trenches up to a height of about 300 mm should be treated by applying insecticide solution (i.e. 4 litres of water with .25% to .5% of aldrin by weight or 0.25% to .5% of Heptachlor by weight) at the rate 5 litres/m<sup>2</sup> of the surface area.

#### b. Treatment of back-fill soil:

The back-fill used to fill the trenches after the masonry walls are constructed, should be treated with .5% of aldrin or .5% of Heptachlor by weight. Solution should be applied on the vertical surface of the foundation masonry at the rate of 7.5% lit/m<sup>2</sup>. If the foundation is made of R.C.C., the treatment should be started at a depth about 0.5 m below ground level and the solution in the back fill at the rate of 7.5% lit/m<sup>2</sup> of vertical surface to be given.

#### c. Treatment of filling at plinth level:

Prior to laying of sub-grade for ground floor, the top surface often consolidated earth filling should be sprinkled with .5% of Aldrin/ Heptachlor at the rate of 5 lit/m<sup>2</sup>.

#### d. Treatment of soil along the external periphery:

The solution of .5% Aldrin/Heptachlor can be injected @ 2.25 lit per metre by 12 mm diameter of 300 mm deep holes at 150 mm c/c distances. If there is apron all along the external wall, then the chemical solution laid on consolidated earth under the apron @ 5 lit/m<sup>2</sup>.

#### ❖ Post construction Treatment:

- e. **Soil treatment of foundation:** : For this dig a trench about .5 m deep all along the wall drives 15 mm diameter holes in the trench at 150 mm c/c. The holes



are to be filled with chemical solution. (.5% of aldrin/.5% of Heptachlor) at the rate 7.5 lit/m<sup>2</sup> of vertical surface of the wall.

- f. **Soil treatment under floor:** All the joints/cracks of floor with walls, can be treated by drilling 12 mm dia. Holes @ 300 mm c/c all along joints and filled with the chemical solution and then the face of the holes to be sealed.
- g. **Treatment of voids in masonry:** Drill 12 mm f holes at 300 mm c/c and fill with the solution.

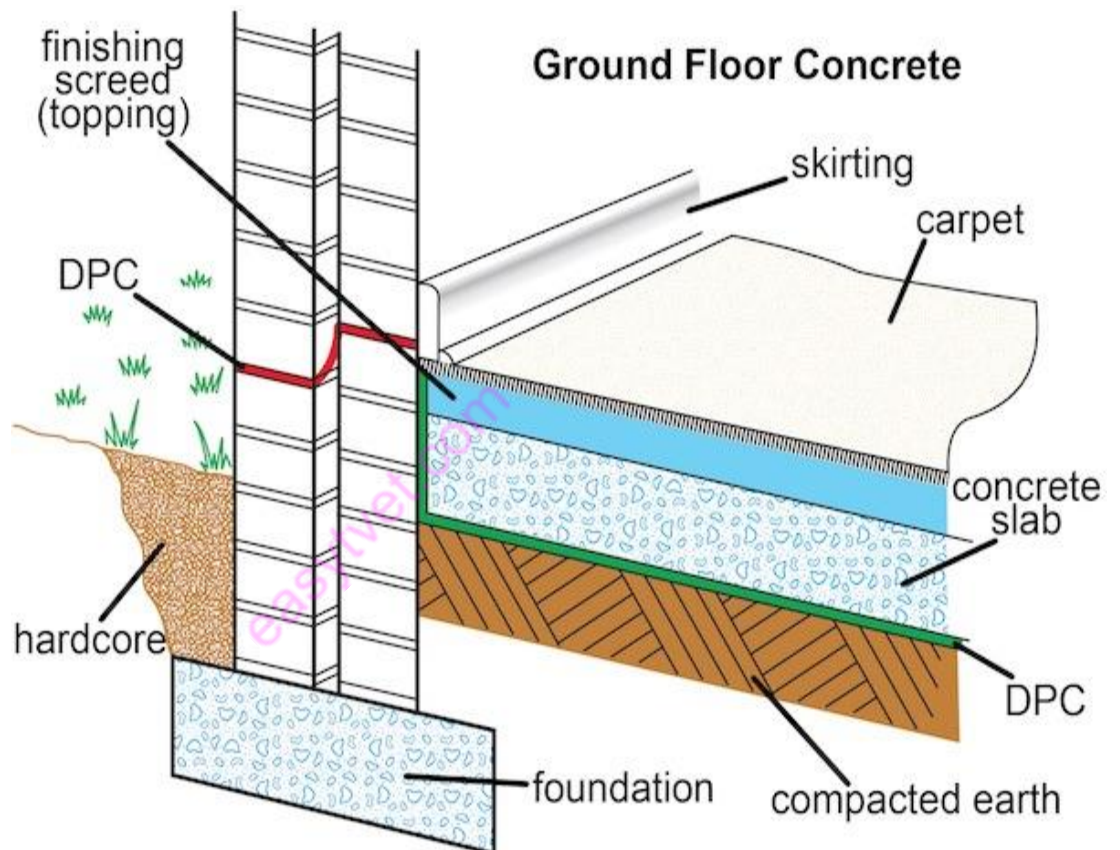

Figure 74: A picture of an illustration of solid ground floor details adopted from: [sans10400.com](http://sans10400.com)

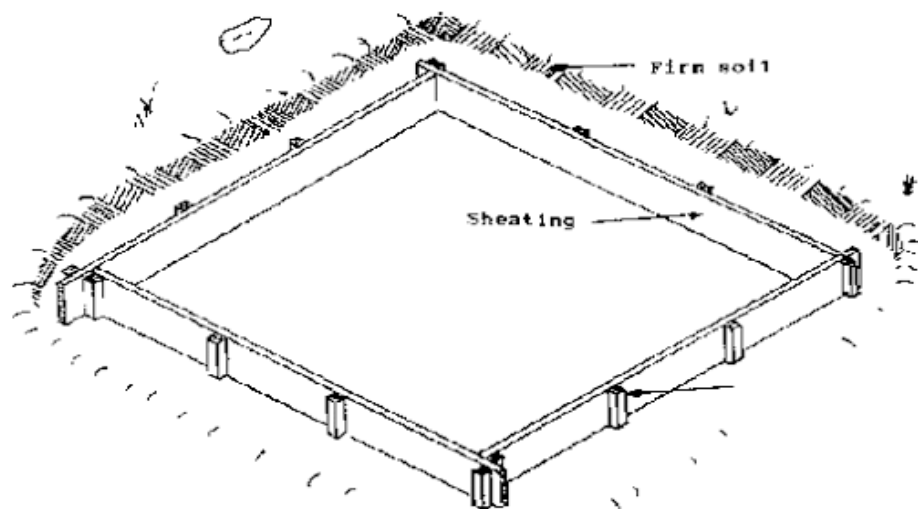

Figure 75: A picture showing positioning of form work of solid ground floor adopted from: [www.nzdi.org](http://www.nzdi.org)

## 5.2.4 Learning Activities

### 5.2.4.1 Practical Activities

**TASK:** Level and compact solid ground floor.

**Special instruction:** Use Building Code (BS 8110 & BS 449).

### 5.2.4.2 Field/Visit to a working construction site

Visit objective/Aim	Indicators	Special instructions
To establish laying and compaction of hard core and blinding layer, spraying of anti-termite laying of DPM and BRC, positioning of spacer block, erection of formwork to slab edges and concreting of solid ground floor.	Procedure followed during laying and compaction of hardcore and blinding layer, spraying of anti-termite, laying of DPM and BRC, positioning of spacer block, erection of formwork concreting of solid ground floor.	As per the specification According to building requirement. As per manufacturers specification.

**Table 1.10: Field visit objectives, indicators and special instructions for-laying and compaction of hard core and blinding layer, spraying of anti-termite laying of DPM and BRC, positioning of spacer block, erection of formwork to slab edges and concreting of solid ground floor.**

### 5.2.5 Self-Assessment

1. Why it is that floor is constructed on a bed of well-compacted hard core?

2. What are some precautions which can be taken to reduce the risk of termite attack in a building during ground floor construction?
3. Why do we use hardcore during construction of solid ground floor?
4. What is the importance of dam proofing a solid ground floor?

### 5.2.6 Tools, Equipment, Supplies and Materials

Tools	Measuring tools Surveying tools Masonry tools
Equipment	Laptops Desktop PCs Masonry equipment
Supplies and materials	Working drawing Printer/plotting device Calculator Internet Timber/steel boards and nails
Resource	A functioning construction site. Building Code (BS 8110 & BS 449)

**Table 1.11: Tools, equipment, supplies and materials for establishment of issuing and recording of required building materials and equipment.**

### 5.2.7 References

Rangwala, S.(Ed)(2009)*Building construction*.

Frank, C. (Ed)(1975)*Building Construction illustrated*.

Roy, C. (Ed) (1973) *Construction Technology*.

Edward, A. (Ed) (1985) *Fundamentals of Building Construction Materials and Method*.

Stephen, C. (Ed) (2006) *Barry's advanced construction of buildings*

### 5.2.8 Responses to Self-Assessment

1. Why it is that floor is constructed on a bed of well-compacted hard core?
  - **It reduces the rise of ground moisture by virtue of the large voids between the pieces of hardcore which eliminate capillary paths;**

- **It provides additional support to the floor above should the ground beneath suffer settlement or subsidence.**
2. What are some precautions which can be taken to reduce the risk of termite attack in a building during ground floor construction
    - **The area around the building should be inspected for termite nests, which should be dug out and treated with insecticide.**
    - **During excavation work for the foundation and hardcore bed, the exposed soil should be treated with insecticide, in an anticipation of termite attack.**
    - **The ground floor concrete should be raised above the adjoining ground level and should project beyond the outer wall face.**
  3. Why do we use hardcore during construction of solid ground floor?
    - **It is be used to provide a firm working surface and to prevent contamination of the lower part of the wet concrete during compaction.**
    - **The hard core materials are hard and durable, not subject to decay or breakdown by weather or chemical attack.**
  4. What is the importance of dam proofing a solid ground floor?
    - **Damp roofing is the principle of preventing moisture entering buildings and causing dampness which might be as a result of water/moisture rising up the wall and floor from the ground forced through the structure, or seeping through the forces of walls.**
    - **Damp proofing helps the prevention of moisture rising up the floor or seeping through walls, causing efflorescence and damage to the walls and floor finishes.**
    - **Generally, damp proofing helps to maintain the quality, strength, stability, durability and resistance to moisture/water of structures.**